

R&S®FPS-K10x (LTE Uplink)

LTE Uplink Measurement Application

User Manual



1176.8816.02 – 05

This manual applies to the following R&S®FPS models with firmware version 1.30 and higher:

- R&S®FPS4 (1319.2008K04)
- R&S®FPS7 (1319.2008K07)
- R&S®FPS13 (1319.2008K13)
- R&S®FPS30 (1319.2008K30)
- R&S®FPS40 (1319.2008K40)

The following firmware options are described:

- R&S FPS-K101 (LTE FDD UL) (1321.4340.02)
- R&S FPS-K103 (LTE UL MIMO) (1321.4356.02)
- R&S FPS-K105 (LTE TDD UL) (1321.4362.02)

© 2015 Rohde & Schwarz GmbH & Co. KG

Mühlhofstr. 15, 81671 München, Germany

Phone: +49 89 41 29 - 0

Fax: +49 89 41 29 12 164

E-mail: info@rohde-schwarz.com

Internet: www.rohde-schwarz.com

Subject to change – Data without tolerance limits is not binding.

R&S® is a registered trademark of Rohde & Schwarz GmbH & Co. KG.

Trade names are trademarks of the owners.

The following abbreviations are used throughout this manual: R&S®FPS is abbreviated as R&S FPS.

Contents

1	Preface	5
1.1	About this Manual.....	5
1.2	Documentation Overview.....	5
1.3	Typographical Conventions.....	7
2	Welcome to the LTE Measurement Application	8
2.1	Starting the LTE Measurement Application.....	8
2.2	Understanding the Display Information.....	9
3	Measurements and Result Displays	11
3.1	I/Q Measurements.....	13
3.2	Frequency Sweep Measurements.....	25
3.3	3GPP Test Scenarios.....	30
4	Measurement Basics	32
4.1	Symbols and Variables.....	32
4.2	Overview.....	33
4.3	The LTE Uplink Analysis Measurement Application.....	33
4.4	SRS EVM Calculation.....	37
5	Configuration	39
5.1	Configuration Overview.....	39
5.2	Configuring I/Q Measurements.....	41
5.3	Configuring Frequency Sweep Measurements.....	73
6	Analysis	78
6.1	Configuring Tables / Numerical Results.....	78
6.2	Analyzing I/Q Measurements.....	78
6.3	Analyzing Frequency Sweep Measurements.....	84
7	Remote Control	85
7.1	Overview of Remote Command Suffixes.....	85
7.2	Introduction.....	86
7.3	Remote Commands to Select the LTE Application.....	91
7.4	General Window Commands.....	94

7.5	Working with Windows in the Display.....	95
7.6	Performing Measurements.....	101
7.7	Remote Commands to Read Trace Data.....	106
7.8	Remote Commands to Read Numeric Results.....	117
7.9	Remote Commands to Read Limit Check Results.....	127
7.10	Remote Commands to Configure the Application.....	136
7.11	Analysis.....	175
	List of Commands.....	182
	Index.....	187

1 Preface

1.1 About this Manual

This LTE User Manual provides all the information **specific to the operating mode**. All general instrument functions and settings common to all applications and operating modes are described in the main R&S FPS User Manual.

The main focus in this manual is on the LTE measurement results and the tasks required to obtain them. The following topics are included:

- **Welcome to the LTE Application**
Introduction to and getting familiar with the application
- **Measurements and Result Displays**
Details on supported LTE measurements and their result types
- **Measurement Basics**
Background information on basic terms and principles in the context of LTE measurements
- **Configuration and Analysis**
A concise description of all functions and settings available to configure and analyze LTE measurements with their corresponding remote control command
- **Optimizing and Troubleshooting the Measurement**
Hints and tips on how to handle errors and optimize the test setup
- **Remote Commands for LTE Measurements**
Remote commands required to configure and perform LTE measurements in a remote environment, sorted by tasks
(Commands required to set up the environment or to perform common tasks on the instrument are provided in the main R&S FPS User Manual)
- **List of remote commands**
Alphabetical list of all remote commands described in the manual
- **Index**

1.2 Documentation Overview

The user documentation for the R&S FPS consists of the following parts:

- Printed Getting Started manual
- Online Help system on the instrument
- Documentation CD-ROM with:
 - Getting Started
 - User Manuals for base unit and firmware applications
 - Service Manual
 - Release Notes

- Data sheet and product brochures

Online Help

The Online Help is embedded in the instrument's firmware. It offers quick, context-sensitive access to the complete information needed for operation and programming. Online help is available using the  icon on the toolbar of the R&S FPS.

Getting Started

This manual is delivered with the instrument in printed form and in PDF format on the CD. It provides the information needed to set up and start working with the instrument. Basic operations and handling are described. Safety information is also included.

The Getting Started manual in various languages is also available for download from the Rohde & Schwarz website, on the R&S FPS product page at <http://www2.rohde-schwarz.com/product/FPS.html>.

User Manuals

User manuals are provided for the base unit and each additional (firmware) application.

The user manuals are available in PDF format - in printable form - on the Documentation CD-ROM delivered with the instrument. In the user manuals, all instrument functions are described in detail. Furthermore, they provide a complete description of the remote control commands with programming examples.

The user manual for the base unit provides basic information on operating the R&S FPS in general, and the Spectrum application in particular. Furthermore, the software functions that enhance the basic functionality for various applications are described here. An introduction to remote control is provided, as well as information on maintenance, instrument interfaces and troubleshooting.

In the individual application manuals, the specific instrument functions of the application are described in detail. For additional information on default settings and parameters, refer to the data sheets. Basic information on operating the R&S FPS is not included in the application manuals.

All user manuals are also available for download from the Rohde & Schwarz website, on the R&S FPS product page at <http://www2.rohde-schwarz.com/product/FPS.html>.

Service Manual

This manual is available in PDF format on the Documentation CD-ROM delivered with the instrument. It describes how to check compliance with rated specifications, instrument function, repair, troubleshooting and fault elimination. It contains all information required for repairing the R&S FPS by replacing modules.

Release Notes

The release notes describe the installation of the firmware, new and modified functions, eliminated problems, and last minute changes to the documentation. The corresponding firmware version is indicated on the title page of the release notes.

The most recent release notes are also available for download from the Rohde & Schwarz website, on the R&S FPS product page at <http://www2.rohde-schwarz.com/product/FPS.html> > Downloads > Firmware.

1.3 Typographical Conventions

The following text markers are used throughout this documentation:

Convention	Description
"Graphical user interface elements"	All names of graphical user interface elements on the screen, such as dialog boxes, menus, options, buttons, and softkeys are enclosed by quotation marks.
KEYS	Key names are written in capital letters.
File names, commands, program code	File names, commands, coding samples and screen output are distinguished by their font.
<i>Input</i>	Input to be entered by the user is displayed in italics.
Links	Links that you can click are displayed in blue font.
"References"	References to other parts of the documentation are enclosed by quotation marks.

2 Welcome to the LTE Measurement Application

The R&S FPS-K101 and -K105 are firmware applications that add functionality to perform measurements on LTE signals according to the 3GPP standard to the R&S FPS.

This user manual contains a description of the functionality that the application provides, including remote control operation. Functions that are not discussed in this manual are the same as in the Spectrum application and are described in the R&S FPS User Manual. The latest versions of the manuals are available for download at the product homepage.

<http://www2.rohde-schwarz.com/product/FPS.html>.

Installation

Find detailed installing instructions in the Getting Started or the release notes of the R&S FPS.

2.1 Starting the LTE Measurement Application

The LTE measurement application adds a new application to the R&S FPS.



Manual operation via an external monitor and mouse

Although the R&S FPS does not have a built-in display, it is possible to operate it interactively in manual mode using a graphical user interface with an external monitor and a mouse connected.

It is recommended that you use the manual mode initially to get familiar with the instrument and its functions before using it in pure remote mode. Thus, this document describes in detail how to operate the instrument manually using an external monitor and mouse. The remote commands are described in the second part of the document. For details on manual operation see the R&S FPS Getting Started manual.

To activate the application

1. Press the MODE key on the front panel of the R&S FPS.

A dialog box opens that contains all operating modes and applications currently available on your R&S FPS.

2. Select the "LTE" item.



The R&S FPS opens a new measurement channel for the LTE measurement application.

The measurement is started immediately with the default settings. It can be configured in the "Overview" dialog box, which is displayed when you select the "Overview" softkey from any menu.

For more information see [chapter 5, "Configuration"](#), on page 39.

2.2 Understanding the Display Information

The following figure shows a measurement diagram during analyzer operation. All different information areas are labeled. They are explained in more detail in the following sections.



- 1 = Toolbar
- 2 = Channel bar
- 3 = Diagram header
- 4 = Result display
- 5 = Subwindows (if more than one MIMO data stream is displayed at the same time)
- 5 = Status bar
- 6 = Softkeys



MSRA operating mode

In MSRA operating mode, additional tabs and elements are available. A colored background of the screen behind the measurement channel tabs indicates that you are in MSRA operating mode. Frequency sweep measurements are not available in MSRA operating mode.

For details on the MSRA operating mode see the R&S FPS MSRA User Manual.

Channel bar information

In the LTE measurement application, the R&S FPS shows the following settings:

Table 2-1: Information displayed in the channel bar in the LTE measurement application

Ref Level	Reference level
Att	Mechanical and electronic RF attenuation
Freq	Frequency
Mode	LTE standard
MIMO	Number of Tx and Rx antennas in the measurement setup
Capture Time	Signal length that has been captured
Frame Count	Number of frames that have been captured
Selected Slot	Slot considered in the signal analysis
Selected Subframe	Subframe considered in the signal analysis

In addition, the channel bar also displays information on instrument settings that affect the measurement results even though this is not immediately apparent from the display of the measured values (e.g. transducer or trigger settings). This information is displayed only when applicable for the current measurement. For details see the R&S FPS Getting Started manual.

Window title bar information

The information in the window title bar depends on the result display.

The "Constellation Diagram", for example, shows the number of points that have been measured.

Status bar information

Global instrument settings, the instrument status and any irregularities are indicated in the status bar beneath the diagram. Furthermore, the progress of the current operation is displayed in the status bar.

Regarding the synchronization state, the application shows the following labels.

- Sync OK
The synchronization was successful. The status bar is green.
- Sync Failed
The synchronization was not successful. The status bar is red.
There can be three different synchronization errors.
 - Sync Failed (Cyclic Prefix): The cyclic prefix correlation failed.
 - Sync Failed (P-SYNC): The P-SYNC correlation failed.
 - Sync Failed (S-SYNC): The S-SYNC correlation failed.

3 Measurements and Result Displays

The LTE measurement application measures and analyzes various aspects of an LTE signal.

It features several measurements and result displays. Measurements represent different ways of processing the captured data during the digital signal processing. Result displays are different representations of the measurement results. They may be diagrams that show the results as a graph or tables that show the results as numbers.

Selecting measurements

- ▶ Press the MEAS key.

The application opens a dialog box that contains several buttons.

Each button represents a set of result displays that thematically belong together and that have a particular display configuration. If these predefined display configurations do not suit your requirements you can add or remove result displays as you like. For more information about selecting result displays see ["Selecting result displays"](#) on page 11.

Depending on what button you select, the application changes the way the R&S FPS capture and processes the raw signal data.

- When you select "EVM", the application processes the I/Q data of the signal. For more information on available I/Q result displays see [chapter 3.1, "I/Q Measurements"](#), on page 13.
When you select one of the result displays available for I/Q measurements, you can combine the result displays available for I/Q measurements in any way.
- When you select "Channel Power ACLR" or "Spectrum Emission Mask", the application performs a frequency sweep. For more information see [chapter 3.2, "Frequency Sweep Measurements"](#), on page 25.
When you select one of the frequency sweep measurements, you can combine the result displays available for the frequency sweep measurements in any way. Note that you can not display the ACLR and SEM at the same time.

Selecting result displays

- ▶ Select the  icon in the toolbar or press the "Display Config" softkey in the "Measurement" menu.

The application enters the SmartGrid configuration mode.

For more information on the SmartGrid functionality see the R&S FPS Getting Started.

In the default state of the application, it shows several conventional result displays.

- Capture Memory
- EVM vs Carrier
- Power Spectrum

- Result Summary
- Constellation Diagram

From that predefined state, add and remove result displays as you like.



Numeric result displays

The application allows you to customize the number of columns for some numeric result displays, for example the Allocation Summary.

To change the displayed columns, tap somewhere in the header row of the table.

The application opens a dialog box to add or remove columns.

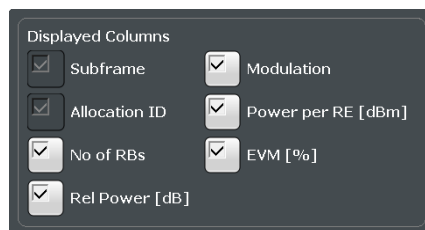

Performing measurements

By default, the application measures the signal continuously. In "Continuous Sweep" mode, the application captures and analyzes the data again and again. The amount of data depends on the capture time (I/Q measurements) or the sweep time (frequency sweep measurements). In "Single Sweep" mode, the application stops measuring after it has captured the data once. The amount of data again depends on the capture time or the sweep time.

You can also repeat a measurement based on the data that has already been captured with the "Refresh" function. This is useful if you want to apply different modulation settings to the same I/Q data, for example.

For more information see the documentation of the R&S FPS.

Selecting the operating mode

The LTE application is supported by the Multi Standard Radio Analyzer (MSRA).

- ▶ Press the MODE key.
- ▶ Select the "Multi-Standard Radio Analyzer Tab".
The R&S FPS enters MSRA mode.

The MSRA mode supports all I/Q measurements and result displays available with the LTE application, except the frequency sweep measurements (SEM and ACLR).

In MSRA operating mode, only the MSRA Master actually captures data. The application receives an extract of the captured data for analysis, referred to as the **application data**. The application data range is defined by the same settings used to define the signal capture in Signal and Spectrum Analyzer mode. In addition, a capture offset can

be defined, i.e. an offset from the start of the captured data to the start of the analysis interval.

If a signal contains multiple data channels for multiple standards, separate applications are used to analyze each data channel. Thus, it is of interest to know which application is analyzing which data channel. The MSRA Master display indicates the data covered by each application by vertical blue lines labeled with the application name. The blue lines correspond to the channel bandwidth which is variable in case of LTE signals.

However, the individual result displays of the application need not analyze the complete data range. The data range that is actually analyzed by the individual result display is referred to as the **analysis interval**.

The analysis interval is automatically determined according to the [Capture Time](#) you have defined. The analysis interval can not be edited directly in the LTE application, but is changed automatically when you change the evaluation range. The currently used analysis interval (in seconds, related to capture buffer start) is indicated in the window header for each result display.

A frequent question when analyzing multi-standard signals is how each data channel is correlated (in time) to others. Thus, an analysis line has been introduced. The analysis line is a common time marker for all MSRA applications. It can be positioned in any MSRA application or the MSRA Master and is then adjusted in all other applications. Thus, you can easily analyze the results at a specific time in the measurement in all applications and determine correlations.

If the marked point in time is contained in the analysis interval of the application, the line is indicated in all time-based result displays, such as time, symbol, slot or bit diagrams. By default, the analysis line is displayed, however, it can be hidden from view manually. In all result displays, the "AL" label in the window title bar indicates whether or not the analysis line lies within the analysis interval or not:

- **orange "AL"**: the line lies within the interval
- **white "AL"**: the line lies within the interval, but is not displayed (hidden)
- **no "AL"**: the line lies outside the interval

For details on the MSRA operating mode see the R&S FPS MSRA documentation.

- [I/Q Measurements](#).....13
- [Frequency Sweep Measurements](#).....25
- [3GPP Test Scenarios](#).....30

3.1 I/Q Measurements

Capture Buffer	14
EVM vs Carrier	14
EVM vs Symbol	15
EVM vs Subframe	16
Power Spectrum	16
Inband Emission	17
Spectrum Flatness	17

Spectrum Flatness SRS..... 18
 Channel Group Delay..... 18
 Spectrum Flatness Difference..... 19
 Constellation Diagram..... 19
 CCDF..... 20
 Allocation Summary..... 20
 Bit Stream..... 21
 EVM vs Sym x Carr..... 21
 Power vs Symbol x Carrier..... 22
 Result Summary..... 22
 Marker Table..... 25

Capture Buffer

The Capture Buffer result display shows the complete range of captured data for the last data capture. The x-axis represents time. The maximum value of the x-axis is equal to the **Capture Time**. The y-axis represents the amplitude of the captured I/Q data in dBm (for RF input).

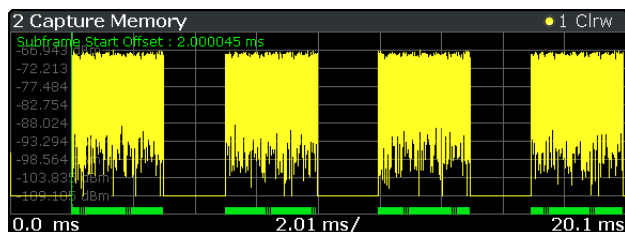

A green vertical line at the beginning of the green bar in the Capture Buffer display marks the subframe start. Additionally, the diagram contains the "Start Offset" value. This value is the time difference between the subframe start and capture buffer start. When you zoom into the diagram, you will see that the bar may be interrupted at certain positions. Each small bar indicates the useful parts of the OFDM symbol.

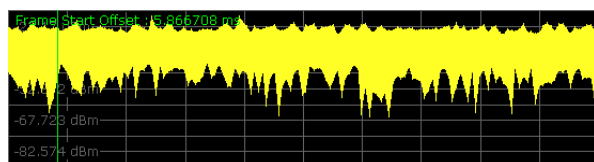

Remote command:

Selecting the result display: `LAY:ADD ? '1',LEFT,CBUF`

Querying results: `TRACe:DATA?`

Querying the subframe start offset: `FETCh:SUMMary:TFRame?` on page 125

EVM vs Carrier

Starts the EVM vs Carrier result display.

This result display shows the Error Vector Magnitude (EVM) of the subcarriers. With the help of a marker, you can use it as a debugging technique to identify any subcarriers whose EVM is too high.

The results are based on an average EVM that is calculated over the resource elements for each subcarrier. This average subcarrier EVM is determined for each analyzed slot in the capture buffer.

If you analyze all slots, the result display contains three traces.

- Average EVM
This trace shows the subcarrier EVM averaged over all slots.
- Minimum EVM
This trace shows the lowest (average) subcarrier EVM that has been found over the analyzed slots.
- Maximum EVM
This trace shows the highest (average) subcarrier EVM that has been found over the analyzed slots.

If you select and analyze one slot only, the result display contains one trace that shows the subcarrier EVM for that slot only. Average, minimum and maximum values in that case are the same. For more information see "[Subframe Selection](#)" on page 79

The x-axis represents the center frequencies of the subcarriers. On the y-axis, the EVM is plotted either in % or in dB, depending on the [EVM Unit](#).

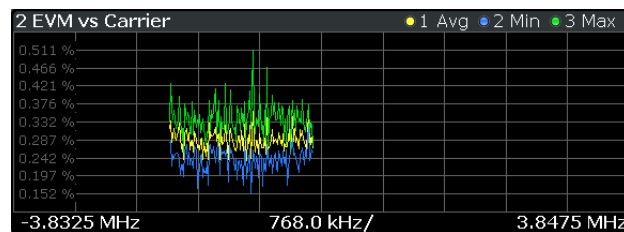

Remote command:

Selecting the result display: `LAY:ADD ? '1',LEFT,EVCA`

Querying results: `TRACe:DATA?`

EVM vs Symbol

Starts the EVM vs Symbol result display.

This result display shows the Error Vector Magnitude (EVM) of the OFDM symbols. You can use it as a debugging technique to identify any symbols whose EVM is too high.

The results are based on an average EVM that is calculated over all subcarriers that are part of a particular OFDM symbol. This average OFDM symbol EVM is determined for all OFDM symbols in each analyzed slot.

If you analyze all subframes, the result display contains three traces.

- Average EVM
This trace shows the OFDM symbol EVM averaged over all slots.
- Minimum EVM
This trace shows the lowest (average) OFDM symbol EVM that has been found over the analyzed slots.
- Maximum EVM
This trace shows the highest (average) OFDM symbol EVM that has been found over the analyzed slots.

If you select and analyze one slot only, the result display contains one trace that shows the OFDM symbol EVM for that slot only. Average, minimum and maximum values in that case are the same. For more information see "[Subframe Selection](#)" on page 79

The x-axis represents the OFDM symbols, with each symbol represented by a dot on the line. The number of displayed symbols depends on the Subframe Selection and the length of the cyclic prefix. Any missing connections from one dot to another mean that the R&S FPS could not determine the EVM for that symbol. In case of TDD signals, the result display does not show OFDM symbols that are not part of the measured link direction.

On the y-axis, the EVM is plotted either in % or in dB, depending on the [EVM Unit](#).

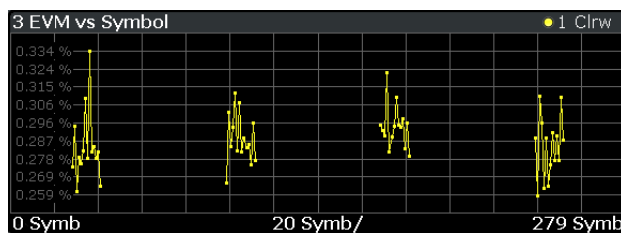

Remote command:

Selecting the result display: `LAY:ADD ? '1',LEFT,EVSY`

Querying results: `TRACe:DATA?`

EVM vs Subframe

Starts the EVM vs Subframe result display.

This result display shows the Error Vector Magnitude (EVM) for each subframe. You can use it as a debugging technique to identify a subframe whose EVM is too high.

The result is an average over all subcarriers and symbols of a specific subframe.

The x-axis represents the subframes, with the number of displayed subframes being 10.

On the y-axis, the EVM is plotted either in % or in dB, depending on the [EVM Unit](#).

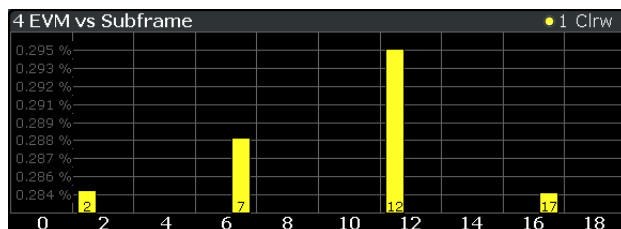

Remote command:

Selecting the result display: `LAY:ADD ? '1',LEFT,EVSU`

Querying results: `TRACe:DATA?`

Power Spectrum

Starts the Power Spectrum result display.

This result display shows the power density of the complete capture buffer in dBm/Hz. The displayed bandwidth depends on bandwidth or number of resource blocks you have set.

For more information see "[Channel Bandwidth / Number of Resource Blocks](#)" on page 43.

The x-axis represents the frequency. On the y-axis the power level is plotted.



Remote command:
 Selecting the result display: `LAY:ADD ? '1',LEFT,PSPE`
 Querying results: `TRACe:DATA?`

Inband Emission

Starts the Inband Emission result display.

This result display shows the relative power of the unused resource blocks (yellow trace) and the inband emission limit lines (red trace) specified by the LTE standard document 3GPP TS36.101.

The measurement is evaluated over the currently selected slot in the currently selected subframe. The currently selected subframe depends on your [selection](#).

Note that you have to select a specific subframe and slot to get valid measurement results.

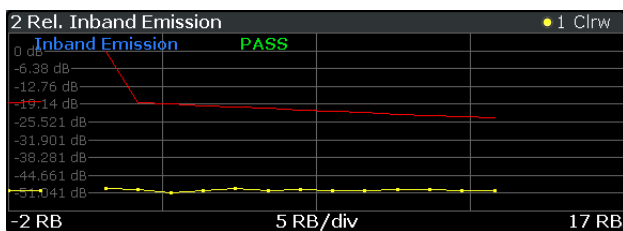

You can also display the inband emissions for the allocated resource block in addition to the unused resource blocks when you select the Inband Emissions All result display.



Remote command:
 Selecting the result display: `LAY:ADD ? '1',LEFT,IE`
 Selecting the result display: `LAY:ADD ? '1',LEFT,IEA`
 Querying results: `TRACe:DATA?`

Spectrum Flatness

Starts the Spectrum Flatness result display.

This result display shows the relative power offset caused by the transmit channel.

The measurement is evaluated over the currently selected slot in the currently selected subframe.

The currently selected subframe depends on your [selection](#).

The x-axis represents the frequency. On the y-axis, the channel flatness is plotted in dB.

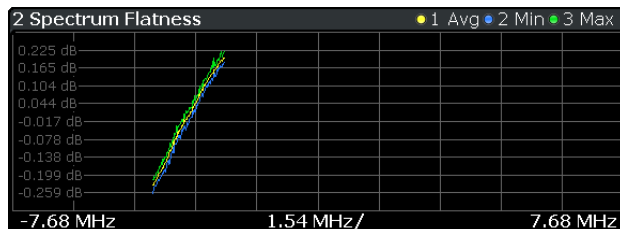

Note that the limit lines are only displayed if you match the [Operating Band](#) to the center frequency. Limits are defined for each operating band in the standard. The shape of the limit line is different when ["Extreme Conditions"](#) on page 46 are on.

Remote command:

Selecting the result display: `LAY:ADD ? '1',LEFT,SFL`

Querying results: `TRACe:DATA?`

Spectrum Flatness SRS

The Spectrum Flatness SRS display shows the amplitude of the channel transfer function based on the sounding reference signal.

The measurement is evaluated over the currently selected slot in the currently selected subframe. The slot and subframe selection may be changed in the general settings.

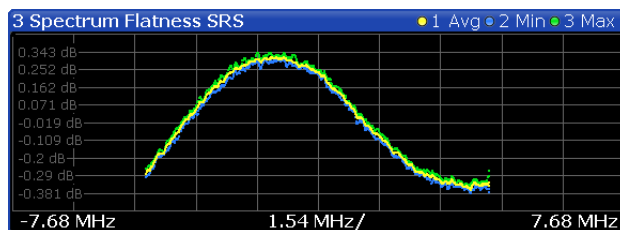

Remote command:

Selecting the result display: `LAY:ADD ? '1',LEFT,SFSR`

Querying results: `TRACe:DATA`

Channel Group Delay

Starts the Channel Group Delay result display.

This result display shows the group delay of each subcarrier.

The measurement is evaluated over the currently selected slot in the currently selected subframe.

The currently selected subframe depends on your [selection](#).

The x-axis represents the frequency. On the y-axis, the group delay is plotted in ns.

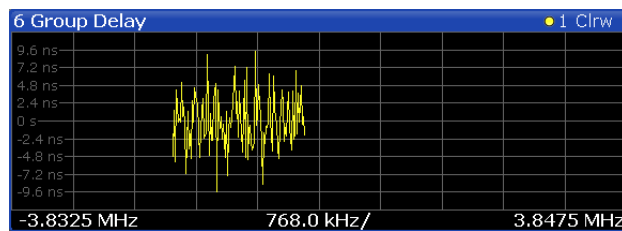

Remote command:

Selecting the result display: `LAY:ADD ? '1',LEFT,GDEL`

Querying results: `TRACe:DATA?`

Spectrum Flatness Difference

Starts the Spectrum Flatness Difference result display.

This result display shows the level difference in the spectrum flatness result between two adjacent physical subcarriers.

The measurement is evaluated over the currently selected slot in the currently selected subframe.

The currently selected subframe depends on your [selection](#).

The x-axis represents the frequency. On the y-axis, the power is plotted in dB.

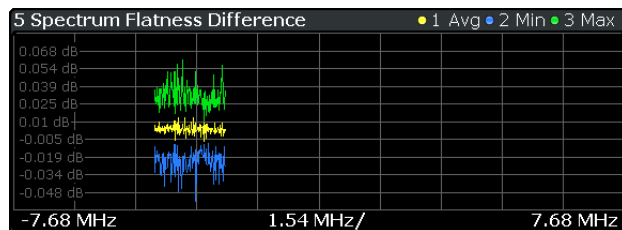

Remote command:

Selecting the result display: `LAY:ADD ? '1',LEFT,SFD`

Querying results: `TRACe:DATA?`

Constellation Diagram

Starts the Constellation Diagram result display.

This result display shows the inphase and quadrature phase results and is an indicator of the quality of the modulation of the signal.

In the default state, the result display evaluates the full range of the measured input data. You can filter the results by changing the [evaluation range](#).

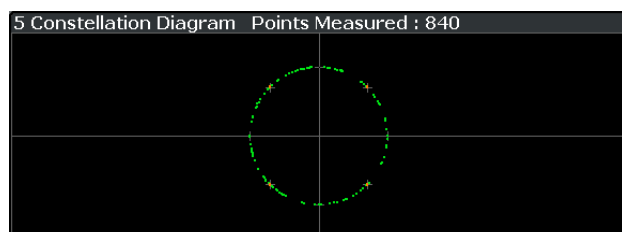

The constellation diagram also contains information about the current **evaluation range**. In addition, it shows the number of points that are displayed in the diagram.

Remote command:

Selecting the result display: `LAY:ADD ? '1',LEFT,CONS`

Querying results: `TRACe:DATA?`

CCDF

Starts the Complementary Cumulative Distribution Function (CCDF) result display.

This result display shows the probability of an amplitude exceeding the mean power. For the measurement, the complete capture buffer is used.

The x-axis represents the power relative to the measured mean power. On the y-axis, the probability is plotted in %.

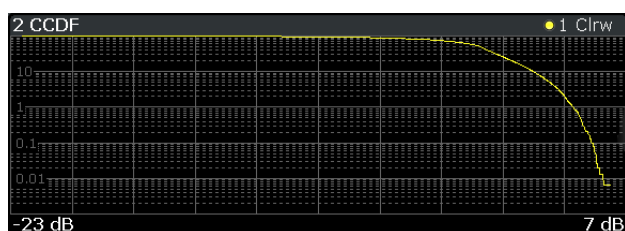

Remote command:

Selecting the result display: `LAY:ADD ? '1',LEFT,CCDF`

Querying results: `TRACe:DATA?`

Allocation Summary

Starts the Allocation Summary result display.

This result display shows the results of the measured allocations in tabular form.

4 Allocation Summary						
Sub-Frame	Allocation ID	No. of RBs	Offset RB	Modulation	Power [dBm]	EVM [%]
2	PUSCH	10	2	QPSK	-30.020	0.285
	DMRS PUSCH			CAZAC	-30.020	0.292
7	PUSCH	10	2	QPSK	-30.019	0.287
	DMRS PUSCH			CAZAC	-30.017	0.297

The rows in the table represent the allocations. A set of allocations form a subframe. The subframes are separated by a dashed line. The columns of the table contain the following information:

- **Subframe**
Shows the subframe number.
- **Allocation ID**
Shows the type / ID of the allocation.
- **Number of RB**
Shows the number of resource blocks assigned to the corresponding allocation.
- **Offset RB**
Shows the resource block offset of the allocation.
- **Modulation**
Shows the modulation type.
- **Power**
Shows the power of the allocation in dBm.
- **EVM**

Shows the EVM of the allocation. The unit depends on your [selection](#).

Note: Contents of the Allocation Summary

The number of columns shown in the Allocation Summary is variable. To add or remove a column, click on the header row of the table *once*. The application opens a dialog box to select the columns which you'd like to display.

Remote command:

Selecting the result display: [LAY:ADD ? '1',LEFT,ASUM](#)

Querying results: [TRACe:DATA?](#)

Bit Stream

Starts the Bit Stream result display.

This result display shows the demodulated data stream for each data allocation. Depending on the [Bit Stream Format](#), the numbers represent either bits (bit order) or symbols (symbol order).

Selecting symbol format shows the bit stream as symbols. In that case the bits belonging to one symbol are shown as hexadecimal numbers with two digits. In the case of bit format, each number represents one raw bit.

Symbols or bits that are not transmitted are represented by a "-".

If a symbol could not be decoded because the number of layers exceeds the number of receive antennas, the application shows a "#" sign.

Sub-Frame	Allocation ID	Codeword	Modulation	Symbol Index	Bit
2	PUSCH	1/1	QPSK	0	02 02 00 03 02 01 02
2	PUSCH	1/1	QPSK	16	01 01 02 00 00 00 03
2	PUSCH	1/1	QPSK	32	00 02 03 00 03 03 02
2	PUSCH	1/1	QPSK	48	00 02 01 02 03 02 02
2	PUSCH	1/1	QPSK	64	01 01 00 03 03 01 01
2	PUSCH	1/1	QPSK	80	00 02 01 03 03 03 03
2	PUSCH	1/1	QPSK	96	03 02 02 02 03 02 00

The table contains the following information:

- **Subframe**
Number of the subframe the bits belong to.
- **Allocation ID**
Channel the bits belong to.
- **Codeword**
Code word of the allocation.
- **Modulation**
Modulation type of the channels.
- **Symbol Index or Bit Index**
Shows the position of the table row's first bit or symbol within the complete stream.
- **Bit Stream**
The actual bit stream.

Remote command:

Selecting the result display: [LAY:ADD ? '1',LEFT,BSTR](#)

Querying results: [TRACe:DATA?](#)

EVM vs Sym x Carr

The EVM vs Symbol x Carrier shows the EVM for each carrier in each symbol.

The horizontal axis represents the symbols. The vertical axis represents the carriers. Different colors in the diagram area represent the EVM. The color map for the power levels is provided above the diagram area.

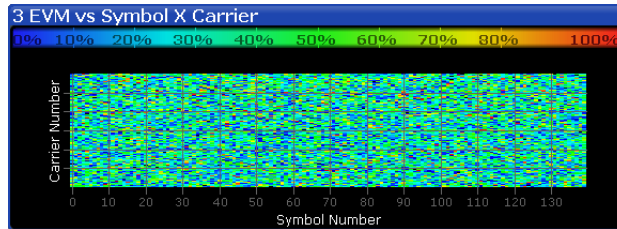

Remote command:

Selecting the result display: `LAY:ADD ? '1',LEFT,EVSC`

Querying results: `TRACe:DATA?`

Power vs Symbol x Carrier

The Power vs Symbol x Carrier shows the power for each carrier in each symbol.

The horizontal axis represents the symbols. The vertical axis represents the carriers. Different colors in the diagram area represent the power. The color map for the power levels is provided above the diagram area.

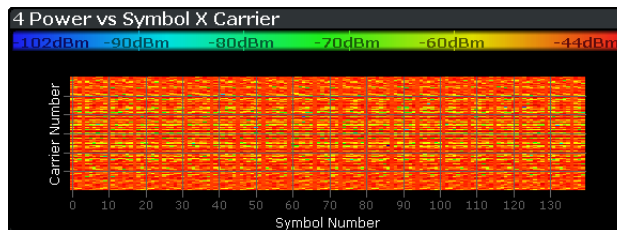

Remote command:

Selecting the result display: `LAY:ADD ? '1',LEFT,PVSC`

Querying results: `TRACe:DATA?`

Result Summary

The Result Summary shows all relevant measurement results in numerical form, combined in one table.

Remote command:

`LAY:ADD ? '1',LEFT,RSUM`

Contents of the result summary

4 Result Summary				
Frame Results 30/30	Mean	Limit	Max	Min
EVM PUSCH QPSK (%)	0.30	17.50		
EVM PUSCH 16QAM (%)		12.50		
EVM DMRS PUSCH QPSK (%)	0.35	17.50		
EVM DMRS PUSCH 16QAM (%)		12.50		
EVM PUCCH (%)		17.50		
EVM DMRS PUCCH (%)		17.50		
Results for Selection	Subframe(s) ALL	Slot(s) ALL	Frame Results 30/30	
EVM All (%)	0.29		0.30	0.28
EVM Phys. Channel (%)	0.29		0.30	0.27
EVM Phys. Signal (%)	0.28		0.31	0.25
Frequency Error (Hz)	-26.65		-26.05	-27.29
Sampling Error (ppm)				
IQ Offset (dB)	-67.10		-63.11	-74.13
IQ Gain Imbalance (dB)				
IQ Quadrature Error (°)				
Power (dBm)	-30.02		-30.02	-30.02
Crest Factor (dB)	5.76		6.21	5.35

4 Result Summary				
3GPP EVM Results	Mean	Limit	Max	Min
EVM PRACH (%)	0.22	17.50		
Results for Selection	Preamble ALL	Preamble Count 2/2		
EVM All (%)	0.22		0.22	0.22
Frequency Error (Hz)	-26.91		-26.77	-27.04
Sampling Error (ppm)				
IQ Offset (dB)	-127.79		-127.70	-127.88
IQ Gain Imbalance (dB)				
IQ Quadrature Error (°)				
Power (dBm)	-26.59		-26.59	-26.59
Crest Factor (dB)	4.50		4.51	4.49

The table is split in two parts. The first part shows results that refer to the complete frame. It also indicates limit check results where available. The font of 'Pass' results is green and that of 'Fail' results is red.

Note that the contents of the table depend on whether you are measuring in PUCCH/ PUSCH or PRACH analysis mode. For more information see "Analysis Mode" on page 71.

In addition to the red font, the application also puts a red star (* 25.60) in front of failed results.

Note: The EVM results on a frame level (first part of the table) are calculated as defined by 3GPP at the edges of the cyclic prefix.

The other EVM results (lower part of the table) are calculated at the optimal timing position in the middle of the cyclic prefix.

Because of inter-symbol interference, the EVM calculated at the edges of the cyclic prefix is higher than the EVM calculated in the middle of the cyclic prefix.

- EVM PUSCH QPSK** Shows the EVM for all QPSK-modulated resource elements of the PUSCH channel in the analyzed frame.
[FETCh:SUMMary:EVM:USQP\[:AVERage\]?](#) on page 120
- EVM PUSCH 16QAM** Shows the EVM for all 16QAM-modulated resource elements of the PUSCH channel in the analyzed frame.
[FETCh:SUMMary:EVM:USST\[:AVERage\]?](#) on page 120
- EVM PUSCH 64QAM** Shows the EVM for all 64QAM-modulated resource elements of the PUSCH channel in the analyzed frame.
[FETCh:SUMMary:EVM:USSF\[:AVERage\]?](#) on page 120

EVM DRMS PUSCH QPSK	Shows the EVM of all DMRS resource elements with QPSK modulation of the PUSCH in the analyzed frame. FETCh:SUMMary:EVM:SDQP[:AVERage]? on page 118
EVM DRMS PUSCH 16QAM	Shows the EVM of all DMRS resource elements with 16QAM modulation of the PUSCH in the analyzed frame. FETCh:SUMMary:EVM:SDST[:AVERage]? on page 118
EVM DRMS PUSCH 64QAM	Shows the EVM of all DMRS resource elements with 64QAM modulation of the PUSCH in the analyzed frame. FETCh:SUMMary:EVM:SDSF[:AVERage]? on page 118
EVM PUCCH	Shows the EVM of all resource elements of the PUCCH channel in the analyzed frame. FETCh:SUMMary:EVM:UCCH[:AVERage]? on page 119
EVM DMRS PUCCH	Shows the EVM of all DMRS resource elements of the PUCCH channel in the analyzed frame. FETCh:SUMMary:EVM:UCCD[:AVERage]? on page 119
EVM PRACH	Shows the EVM of all resource elements of the PRACH channel in the analyzed frame. FETCh:SUMMary:EVM:UPRA[:AVERage]? on page 119

By default, all EVM results are in %. To view the EVM results in dB, change the [EVM Unit](#).

The second part of the table shows results that refer to a specific selection of the frame.

The statistic is always evaluated over the slots.

The header row of the table contains information about the selection you have made (like the subframe).

EVM All	Shows the EVM for all resource elements in the analyzed frame. FETCh[:CC<cci>]:SUMMary:EVM[:ALL][:AVERage]? on page 121
EVM Phys Channel	Shows the EVM for all physical channel resource elements in the analyzed frame. A physical channel corresponds to a set of resource elements carrying information from higher layers. PUSCH, PUCCH and PRACH are physical channels. For more information see 3GPP 36.211. FETCh[:CC<cci>]:SUMMary:EVM:PChannel[:AVERage]? on page 122
EVM Phys Signal	Shows the EVM for all physical signal resource elements in the analyzed frame. The reference signal is a physical signal. For more information see 3GPP 36.211. FETCh[:CC<cci>]:SUMMary:EVM:PSIGnal[:AVERage]? on page 122
Frequency Error	Shows the difference in the measured center frequency and the reference center frequency. FETCh[:CC<cci>]:SUMMary:FERRor[:AVERage]? on page 123
Sampling Error	Shows the difference in measured symbol clock and reference symbol clock relative to the system sampling rate. FETCh[:CC<cci>]:SUMMary:SERRor[:AVERage]? on page 125

I/Q Offset	Shows the power at spectral line 0 normalized to the total transmitted power. FETCh[:CC<cci>]:SUMMARY:IQOffset[:AVERage]? on page 123
I/Q Gain Imbalance	Shows the logarithm of the gain ratio of the Q-channel to the I-channel. FETCh[:CC<cci>]:SUMMARY:GIMBalance[:AVERage]? on page 123
I/Q Quadrature Error	Shows the measure of the phase angle between Q-channel and I-channel deviating from the ideal 90 degrees. FETCh[:CC<cci>]:SUMMARY:QUADerror[:AVERage]? on page 124
Power	Shows the average time domain power of the allocated resource blocks of the analyzed signal. FETCh[:CC<cci>]:SUMMARY:POWer[:AVERage]? on page 124
Crest Factor	Shows the peak-to-average power ratio of captured signal. FETCh[:CC<cci>]:SUMMARY:CRESt[:AVERage]? on page 121

Marker Table

Displays a table with the current marker values for the active markers.

4 Marker Table						
Wnd	Type	Ref	Trc	X-value	Y-value	
1	M1		1	13.25 GHz	-200.0 dBm	
1	D2	M1	1	-600.0 kHz	0.0 dB	
1	D3	M1	1	600.0 kHz	0.0 dB	
1	D4	M1	1	-2.0 MHz	0.0 dB	

Remote command:

LAY:ADD? '1',RIGH, MTAB, see [LAYout:ADD\[:WINDow\]? on page 95](#)

Results:

[CALCulate<n>:MARKer<m>:X on page 126](#)

[CALCulate<n>:MARKer<m>:Y? on page 127](#)

3.2 Frequency Sweep Measurements

The Spectrum Emission Mask (SEM) and Adjacent Channel Leakage Ratio (ACLR) measurements are the only frequency sweep measurements available for the LTE measurement application. They do not use the I/Q data all other measurements use. Instead those measurements sweep the frequency spectrum every time you run a new measurement. Therefore it is not possible to run an I/Q measurement and then view the results in the frequency sweep measurements and vice-versa. Also because each of the frequency sweep measurements uses different settings to obtain signal data it is not possible to run a frequency sweep measurement and view the results in another frequency sweep measurement.

Frequency sweep measurements are available if RF input is selected.

ACLR	26
Spectrum Mask	27
Multi Carrier ACLR	28

ACLR

Starts the Adjacent Channel Leakage Ratio (ACLR) measurement.

The ACLR measurement analyzes the power of the transmission (TX) channel and the power of the two neighboring channels (adjacent channels) to the left and right of the TX channel. Thus, the ACLR measurement provides information about the power in the adjacent channels as well as the leakage into these adjacent channels.

The x-axis represents the frequency with a frequency span that relates to the specified EUTRA/LTE channel and adjacent channel bandwidths. On the y-axis, the power is plotted in dBm.

By default the ACLR settings are based on the selected LTE Channel Bandwidth. You can change the assumed adjacent channel carrier type and, if required, customize the channel setup to your needs. For more information see the documentation of the R&S FPS.

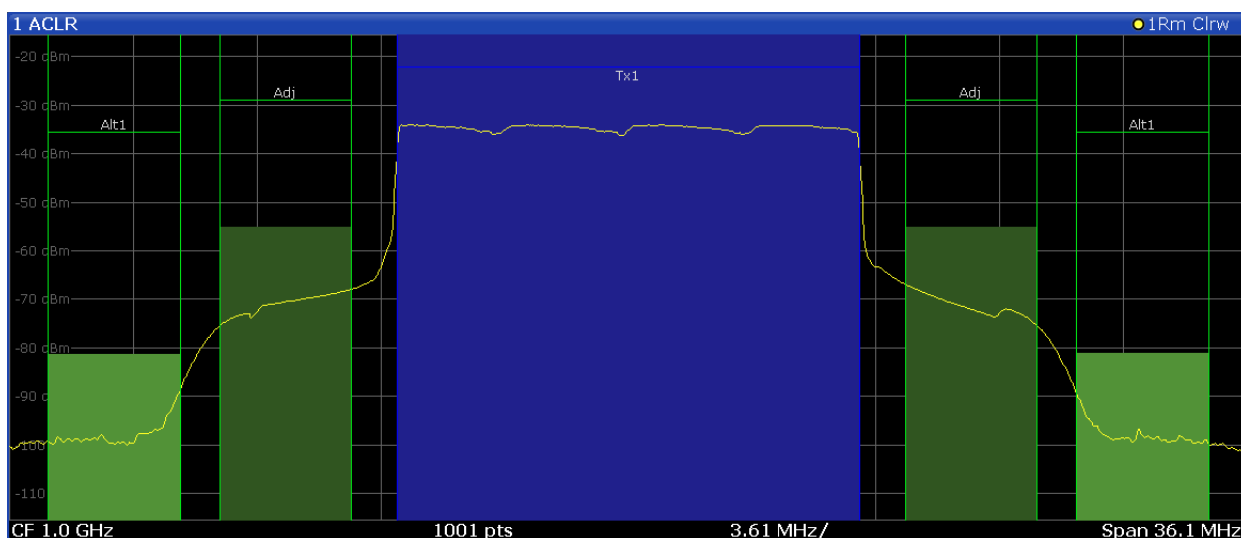

The power for the TX channel is an absolute value in dBm. The power of the adjacent channels are values relative to the power of the TX channel.

In addition, the ACLR measurement results are also tested against the limits defined by 3GPP. In the diagram, the limits are represented by horizontal red lines.

ACLR table

A table above the result display contains information about the measurement in numerical form:

- **Channel**
Shows the channel type (TX, Adjacent or Alternate Channel).
- **Bandwidth**
Shows the bandwidth of the channel.
- **Spacing**
Shows the channel spacing.
- **Lower / Upper**
Shows the relative power of the lower and upper adjacent and alternate channels
- **Limit**
Shows the limit of that channel, if one is defined.

2 Result Summary		EUTRA/LTE Square/RRC		
Channel	Bandwidth	Offset	Power	
Tx1 (Ref)	13.500 MHz		-13.56 dBm	
Tx Total			-13.56 dBm	
Channel	Bandwidth	Offset	Lower	Upper
Adj	3.840 MHz	10.000 MHz	-41.48 dB	-41.66 dB
Alt1	3.840 MHz	15.000 MHz	-67.74 dB	-67.62 dB

Remote command:

Selecting the result display:

`CONF:MEAS ACLR`

Querying results:

`CALCulate<n>:MARKer<m>:FUNction:POWER:RESult[:CURRent]?`

`TRACe:DATA?`

Spectrum Mask

Starts the Spectrum Emission Mask (SEM) result display.

(Note that the SEM measurement also supports carrier aggregation up to two contiguous component carriers. You can configure the component carriers in the [Carrier Aggregation](#) panel.)

The Spectrum Emission Mask measurement shows the quality of the measured signal by comparing the power values in the frequency range near the carrier against a spectral mask that is defined by the 3GPP specifications. In this way, you can test the performance of the DUT and identify the emissions and their distance to the limit.

In the diagram, the SEM is represented by a red line. If any measured power levels are above that limit line, the test fails. If all power levels are inside the specified limits, the test is passed. The application labels the limit line to indicate whether the limit check has passed or failed.

The x-axis represents the frequency with a frequency span that relates to the specified EUTRA/LTE channel bandwidths. On the y-axis, the power is plotted in dBm.

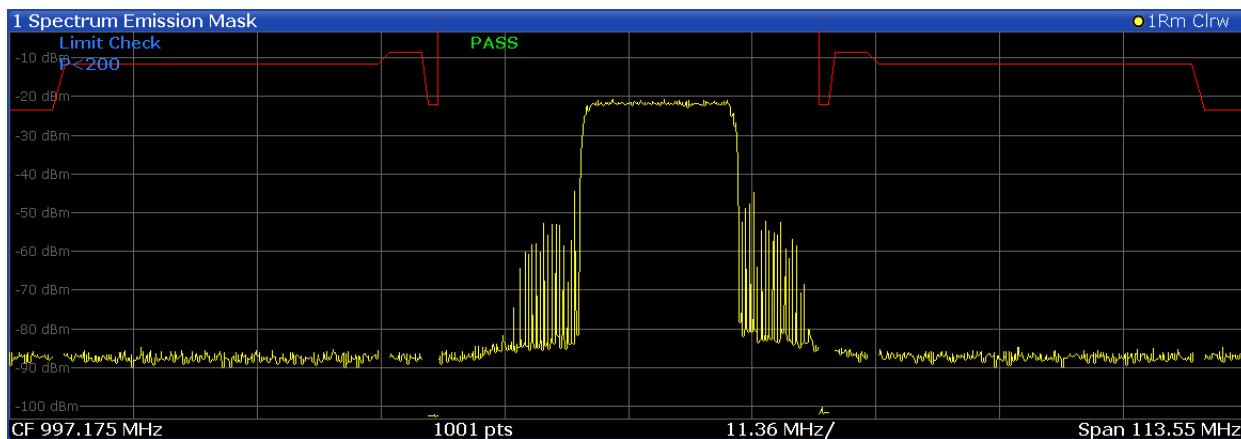

A table above the result display contains the numerical values for the limit check at each check point:

- **Start / Stop Freq Rel**
Shows the start and stop frequency of each section of the Spectrum Mask relative to the center frequency.
- **RBW**
Shows the resolution bandwidth of each section of the Spectrum Mask

- Freq at Δ to Limit**
 Shows the absolute frequency whose power measurement being closest to the limit line for the corresponding frequency segment.
- Power Abs**
 Shows the absolute measured power of the frequency whose power is closest to the limit. The application evaluates this value for each frequency segment.
- Power Rel**
 Shows the distance from the measured power to the limit line at the frequency whose power is closest to the limit. The application evaluates this value for each frequency segment.
- Δ to Limit**
 Shows the minimal distance of the tolerance limit to the SEM trace for the corresponding frequency segment. Negative distances indicate the trace is below the tolerance limit, positive distances indicate the trace is above the tolerance limit.

2 Result Summary						
Sub Block A		Center 997.18 MHz	Tx Power -10.69 dBm	RBW 30.000 kHz		
			Tx Bandwidth 34.850 MHz	LTE UL		
Range Low	Range Up	RBW	Frequency	Power Abs	Power Rel	ΔLimit
-56.775 MHz	-52.775 MHz	1.000 MHz	942.78889 MHz	-85.96 dBm	-75.26 dB	-62.46 dB
-51.775 MHz	-22.925 MHz	1.000 MHz	972.13506 MHz	-85.54 dBm	-74.85 dB	-74.04 dB
-21.925 MHz	-18.925 MHz	1.000 MHz	977.86111 MHz	-86.04 dBm	-75.35 dB	-77.54 dB
-18.410 MHz	-17.440 MHz	30.000 kHz	979.43187 MHz	-102.33 dBm	-91.64 dB	-80.33 dB
17.440 MHz	18.410 MHz	30.000 kHz	1.01492 GHz	-100.40 dBm	-89.70 dB	-78.40 dB
18.925 MHz	21.925 MHz	1.000 MHz	1.01671 GHz	-85.18 dBm	-74.49 dB	-76.68 dB
22.925 MHz	51.775 MHz	1.000 MHz	1.03284 GHz	-84.80 dBm	-74.11 dB	-73.30 dB
52.775 MHz	56.775 MHz	1.000 MHz	1.05167 GHz	-84.80 dBm	-74.11 dB	-61.30 dB

Remote command:
 Selecting the result display: [CONF:MEAS ESP](#)
 Querying results: [TRACe:DATA?](#)

Multi Carrier ACLR

Starts the Multi Carrier Adjacent Channel Leakage Ratio (MC ACLR) measurement. The MC ACLR measurement is basically the same as the [ACLR](#) measurement: it measures the power of the transmission channels and neighboring channels and their effect on each other. Instead of measuring a single carrier, the MC ACLR measures two contiguous component carriers. You can configure the component carriers in the [Carrier Aggregation](#) panel. Note that the component carriers have to be next to each other.

In its default state, the MC ACLR measurement measures three neighboring channels above and below the carrier. One of the neighboring channels is assumed to be an EUTRA channel (for example LTE) and the other two are assumed to be UTRA channels (for example WCDMA). Note that you can configure a different neighboring channel setup with the tools provided by the measurement. These tools are the same as those provided in the Spectrum application. For more information, please refer to the documentation of the R&S FSW.

The configuration in its default state complies with the test specifications defined in 3GPP 36.521.

The x-axis represents the frequency with a frequency span that relates to the LTE channel characteristics and adjacent channel bandwidths. Note that the application automatically determines the center frequency of the measurement according to the frequencies of the carriers.

On the y-axis, the power is plotted in dBm. The power for the TX channels is an absolute value in dBm. The power of the adjacent channels are values relative to the power of the TX channel. The power of the channels is automatically tested against the limits defined by 3GPP.

The result display contains several additional elements.

- **Blue and green lines:**
Represent the bandwidths of the carriers (blue lines) and those of the neighboring channels (green lines). Note that the channels may overlap each other.
- **Blue and green bars:**
Represent the integrated power of the transmission channels (blue bars) and neighboring channels (green bars).

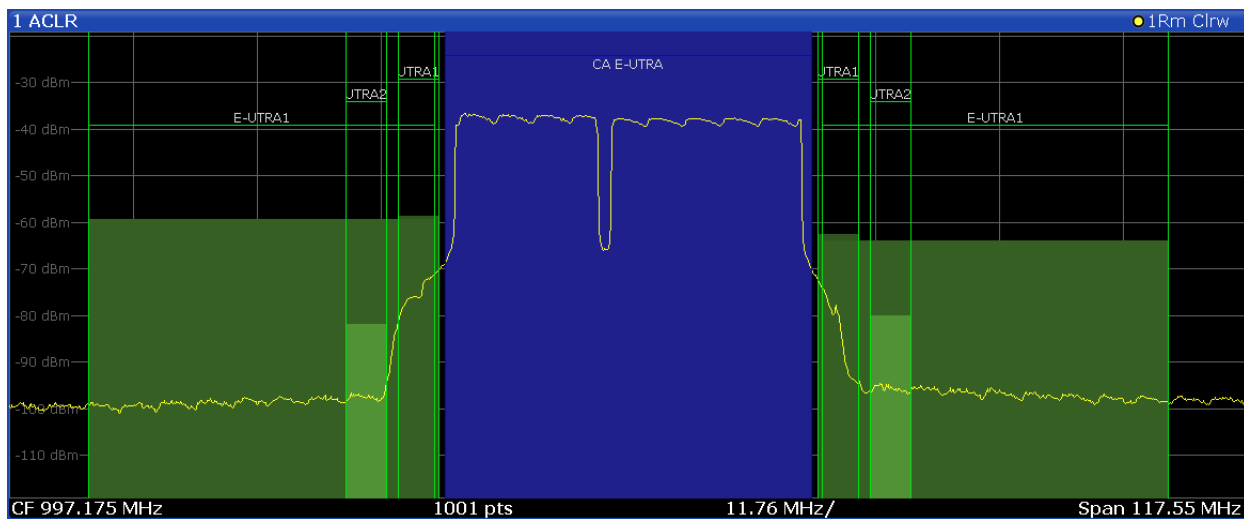

MC ACLR table

A table above the result display contains information about the measurement in numerical form:

- **Channel**
Shows the type of channel.
The first two rows represent the aggregated carrier (CA EUTRA Ref and Total: both rows show the characteristics of the aggregated channel and thus are basically the same). Regarding its characteristics, the two carriers are regarded as a single channel.
The other rows represent the neighboring channels (one E-UTRA and two UTRA channels).
The other rows represent the neighboring channels (Adj Lower / Upper and Alt1 Lower / Upper).
- **Bandwidth**
Shows the bandwidth of the channel.
The bandwidth of the carrier is the sum of the two component carriers.
- **Offset**
Frequency offset relative to the center frequency of the aggregated carrier.
- **Power / Lower / Upper / Gap**
Shows the power of the carrier and the power of the lower and upper neighboring channels relative to the power of the aggregated carrier.

2 Result Summary		LTE Carrier Aggregation		
Channel	Bandwidth	Offset	Power	
CA E-UTRA (Ref)	34.850 MHz		-13.19 dBm	
Tx Total			-13.19 dBm	
Channel	Bandwidth	Offset	Lower	Upper
UTRA1	3.840 MHz	19.925 MHz	-45.42 dB	-49.33 dB
UTRA2	3.840 MHz	24.925 MHz	-68.67 dB	-66.96 dB
E-UTRA1	32.850 MHz	34.850 MHz	-46.26 dB	-50.88 dB

Note that the font of the results turns red if the signal violates the limits defined by 3GPP.

Remote command:

Selecting the result display:

[CONF:MEAS MCAC](#)

Querying results:

[CALCulate<n>:MARKer<m>:FUNCTION:POWER:RESult\[:CURRENT\]?](#)

[TRACe:DATA?](#)

Querying limit check results:

[CALCulate<n>:LIMit<k>:ACPower:ACHannel:RESult?](#) on page 127

[CALCulate<n>:LIMit<k>:ACPower:ALternate:RESult?](#) on page 128

3.3 3GPP Test Scenarios

3GPP defines several test scenarios for measuring user equipment. These test scenarios are described in detail in 3GPP TS 36.521-1.

The following table provides an overview which measurements available in the LTE application are suited to use for the test scenarios in the 3GPP documents.

Table 3-1: Test scenarios for E-TMs as defined by 3GPP (3GPP TS 36.521-1)

Test scenario	Test described in	Measurement
UE Maximum Output Power	chapter 6.2.2	Power (→ Result Summary)
Maximum Power Reduction	chapter 6.2.3	Power (→ Result Summary)
Additional Maximum Power Reduction	chapter 6.2.4	Power (→ Result Summary)
Configured UE-transmitted Output Power	chapter 6.2.5	Power (→ Result Summary)
Minimum Output Power	chapter 6.3.2	Power (→ Result Summary)
Transmit Off Power	chapter 6.3.3	n/a
On/Off Time Mask	chapter 6.3.4	n/a
Power Control	chapter 6.3.5	n/a
Frequency Error	chapter 6.5.1	Frequency Error (→ Result Summary)
Transmit Modulation	chapter 6.5.2.1	EVM results
	chapter 6.5.2.2	I/Q Offset (→ Result Summary)
	chapter 6.5.2.3	Inband Emission

Test scenario	Test described in	Measurement
	chapter 6.5.2.4	Spectrum Flatness
Occupied Bandwidth	chapter 6.6.1	Occupied Bandwidth ¹
Out of Band Emission	chapter 6.6.2.1	Spectrum Emission Mask
	chapter 6.6.2.2	Spectrum Emission Mask
	chapter 6.6.2.3	ACLR
Spurious Emissions	chapter 6.6.3.1	Spurious Emissions ¹
	chapter 6.6.3.2	Spurious Emissions ¹
	chapter 6.6.3.3	Spurious Emissions ¹
Transmit Intermodulation	chapter 6.7	ACLR
Time Alignment	chapter 6.8	Time Alignment

¹these measurements are available in the Spectrum application of the Rohde & Schwarz signal and spectrum analyzers (for example the R&S FSW)

4 Measurement Basics

• Symbols and Variables	32
• Overview	33
• The LTE Uplink Analysis Measurement Application	33
• SRS EVM Calculation	37

4.1 Symbols and Variables

The following chapters use various symbols and variables in the equations that the measurements are based on. The table below explains these symbols for a better understanding of the measurement principles.

$a_{i,k}, \hat{a}_{i,k}$	data symbol (actual, decided)
$A_{i,k}$	data symbol after DFT-precoding
$\Delta f, \Delta \hat{f}_{\text{coarse}}$	carrier frequency offset between transmitter and receiver (actual, coarse estimate)
Δf_{res}	residual carrier frequency offset
ζ	relative sampling frequency offset
$H_{i,k}, \hat{H}_{i,k}$	channel transfer function (actual, estimate)
i	time index
$\hat{t}_{\text{coarse}}, \hat{t}_{\text{fine}}$	timing estimate (coarse, fine)
k	subcarrier index
l	SC-FDMA symbol index
N_{DS}	number of SC-FDMA data symbols
N_{FFT}	length of FFT
N_g	number of samples in cyclic prefix (guard interval)
N_s	number of Nyquist samples
N_{TX}	number of allocated subcarriers
$N_{k,l}$	noise sample
n	index of modulated QAM symbol before DFT precoding
Φ_l	common phase error
r_i	received sample in the time domain
$R'_{k,l}$	uncompensated received sample in the frequency domain

$r_{n,l}$	equalized received symbols of measurement path after IDFT
T	duration of the useful part of an SC-FDMA symbol
T_g	duration of the guard interval
T_s	total duration of SC-FDMA symbol

4.2 Overview

The digital signal processing (DSP) involves several stages until the software can present results like the EVM.



The contents of this chapter are structured like the DSP.

4.3 The LTE Uplink Analysis Measurement Application

The block diagram in [figure 4-1](#) shows the general structure of the LTE uplink measurement application from the capture buffer containing the I/Q data up to the actual analysis block.

After synchronization a fully compensated signal is produced in the reference path (purple) which is subsequently passed to the equalizer. An IDFT of the equalized symbols yields observations for the QAM transmit symbols $a_{n,l}$ from which the data estimates $\hat{a}_{n,l}$ are obtained via hard decision. Likewise a user defined compensation as well as equalization is carried out in the measurement path (cyan) and after an IDFT the observations of the QAM transmit symbols are provided. Accordingly, the measurement path might still contain impairments which are compensated in the reference path. The symbols of both signal processing paths form the basis for the analysis.

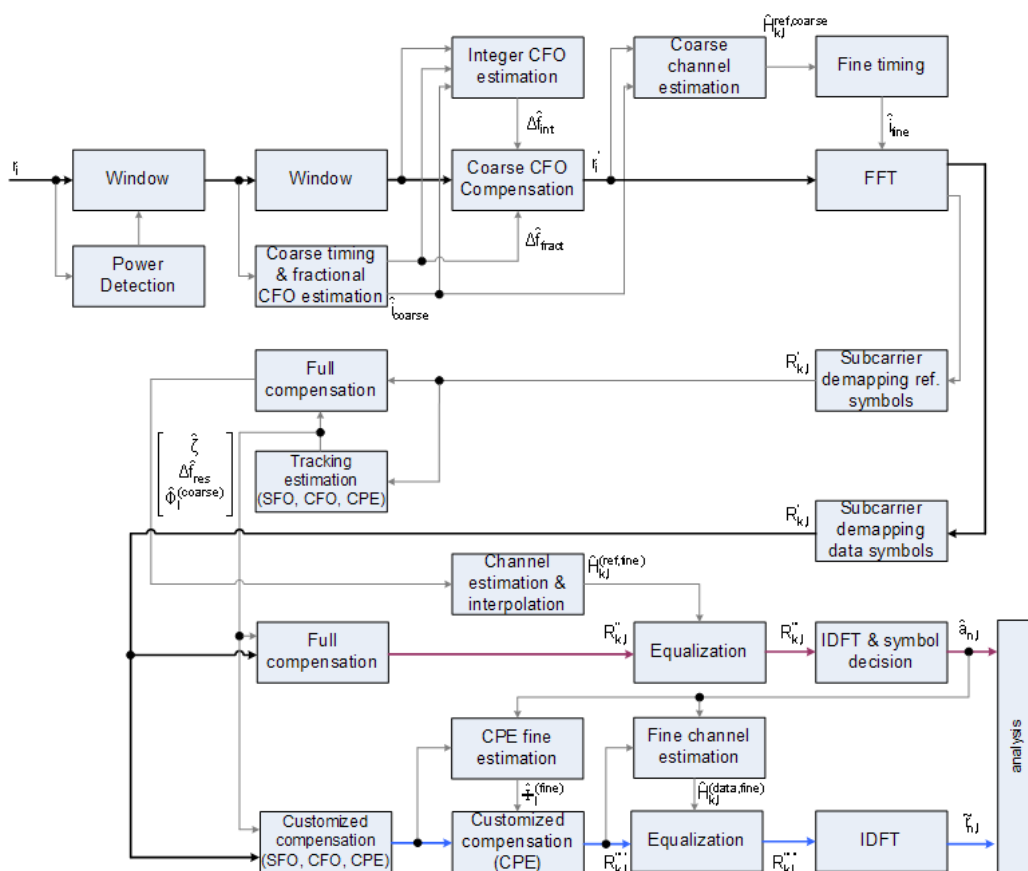

Fig. 4-1: Block diagram for the LTE UL measurement application

4.3.1 Synchronization

In a first step the areas of sufficient power are identified within the captured I/Q data stream which consists of the receive samples r_i . For each area of sufficient power, the analyzer synchronizes on subframes of the uplink generic frame structure [3]. After this coarse timing estimation, the fractional part as well as the integer part of the carrier frequency offset (CFO) are estimated and compensated. In order to obtain an OFDM demodulation via FFT of length N_{FFT} that is not corrupted by ISI, a fine timing is established which refines the coarse timing estimate.

A phase tracking based on the reference SC-FDMA symbols is performed in the frequency domain. The corresponding tracking estimation block provides estimates for

- the relative sampling frequency offset ζ
- the residual carrier frequency offset Δf_{res}
- the common phase error Φ_1

According to references [7] and [8], the uncompensated samples $R'_{k,l}$ in the DFT-pre-coded domain can be stated as

$$R'_{k,l} = A_{k,l} \cdot H_{k,l} \cdot \underbrace{e^{j\Phi_l}}_{\leftarrow \text{CPE}} \cdot \underbrace{e^{j2\pi \cdot N_S / N_{FFT} \cdot \zeta \cdot k \cdot l}}_{\leftarrow \text{SFO}} \cdot \underbrace{e^{j2\pi \cdot N_S / N_{FFT} \cdot \Delta f_{res} \cdot T \cdot l}}_{\leftarrow \text{res.CFO}} + N_{k,l} \quad (4 - 1)$$

with

- the DFT precoded data symbol $A_{k,l}$ on subcarrier k at SC-FDMA symbol l ,
- the channel transfer function $H_{k,l}$,
- the number of Nyquist samples N_S within the total duration T_S ,
- the duration of the useful part of the SC-FDMA symbol $T = T_S - T_g$
- the independent and Gaussian distributed noise sample $N_{k,l}$

Within one SC-FDMA symbol, both the CPE and the residual CFO cause the same phase rotation for each subcarrier, while the rotation due to the SFO depends linearly on the subcarrier index. A linear phase increase in symbol direction can be observed for the residual CFO as well as for the SFO.

The results of the tracking estimation block are used to compensate the samples $R'_{k,l}$ completely in the reference path and according to the user settings in the measurement path. Thus the signal impairments that are of interest to the user are left uncompensated in the measurement path.

After having decoded the data symbols in the reference path, an additional data-aided phase tracking can be utilized to refine the common phase error estimation.

4.3.2 Analysis

The analysis block of the EUTRA/LTE uplink measurement application allows to compute a variety of measurement variables.

EVM

The most important variable is the error vector magnitude which is defined as

$$EVM_{l,k} = \frac{|\tilde{r}_{n,l} - \hat{a}_{n,l}|}{\sqrt{E\{|a_{n,l}|^2\}}} \quad (4 - 2)$$

for QAM symbol n before precoding and SC-FDMA symbol l . Since the normalized average power of all possible constellations is 1, the equation can be simplified to

$$EVM_{n,l} = |\tilde{r}_{n,l} - \hat{a}_{n,l}| \quad (4 - 3)$$

The average EVM of all data subcarriers is then

$$EVM_{data} = \sqrt{\frac{1}{N_{DS}N_{TX}} \sum_{l=0}^{N_{LB}-1} \sum_{n=0}^{N_{TX}-1} EVM_{n,l}^2}$$

(4 - 4)

for N_{DS} SC-FDMA data symbols and the N_{TX} allocated subcarriers.

I/Q imbalance

The I/Q imbalance contained in the continuous received signal $r(t)$ can be written as

$$r(t) = I \Re\{s(t)\} + jQ \Im\{s(t)\}$$

(4 - 5)

where $s(t)$ is the transmit signal and I and Q are the weighting factors describing the I/Q imbalance. We define that $I:=1$ and $Q:=1+\Delta Q$.

The I/Q imbalance estimation makes it possible to evaluate the

$$\text{modulator gain balance} = |1 + \Delta Q|$$

(4 - 6)

and the

$$\text{quadrature mismatch} = \arg\{1 + \Delta Q\}$$

(4 - 7)

based on the complex-valued estimate $\Delta \hat{Q}$.

Basic in-band emissions measurement

The in-band emissions are a measure of the interference falling into the non-allocated resources blocks.

The relative in-band emissions are given by

$$Emissions_{relative}(\Delta_{RB}) = \frac{Emissions_{absolute}(\Delta_{RB})}{\frac{1}{|T_S| \cdot N_{RB}} \sum_{t \in T_S} \sum_c^{c+12 \cdot N_{RB}-1} |Y(t, f)|^2}$$

(4 - 8)

where T_S is a set $|T_S|$ of SC-FDMA symbols with the considered modulation scheme being active within the measurement period, Δ_{RB} is the starting frequency offset between the allocated RB and the measured non-allocated RB (e.g. $\Delta_{RB}=1$ or $\Delta_{RB}=-1$ for the first adjacent RB), c is the lower edge of the allocated BW, and $Y(t, f)$ is the frequency domain signal evaluated for in-band emissions. N_{RB} is the number of allocated RBs.

The basic in-band emissions measurement interval is defined over one slot in the time domain.

Other measurement variables

Without going into detail, the EUTRA/LTE uplink measurement application additionally provides the following results:

- Total power
- Constellation diagram
- Group delay
- I/Q offset
- Crest factor
- Spectral flatness

4.4 SRS EVM Calculation

In order to calculate an accurate EVM, a channel estimation needs to be done prior to the EVM calculation. However, the channel estimation requires a minimum of two resource elements containing reference symbols on a subcarrier. Depending on the current [Channel Estimation Range](#) setting, this means that either at least two reference symbols ("Pilot Only") or one reference symbol and at least one data symbol ("Pilot and Payload") need to be available on the subcarrier the EVM is to be measured.

For PUSCH, PUCCH and PRACH regions, these conditions are normally fulfilled because the DMRS (= Demodulation Reference Signal) is already included. However, the SRS may also be located on subcarriers which do not occupy any other reference symbols (see [figure 4-2](#)).

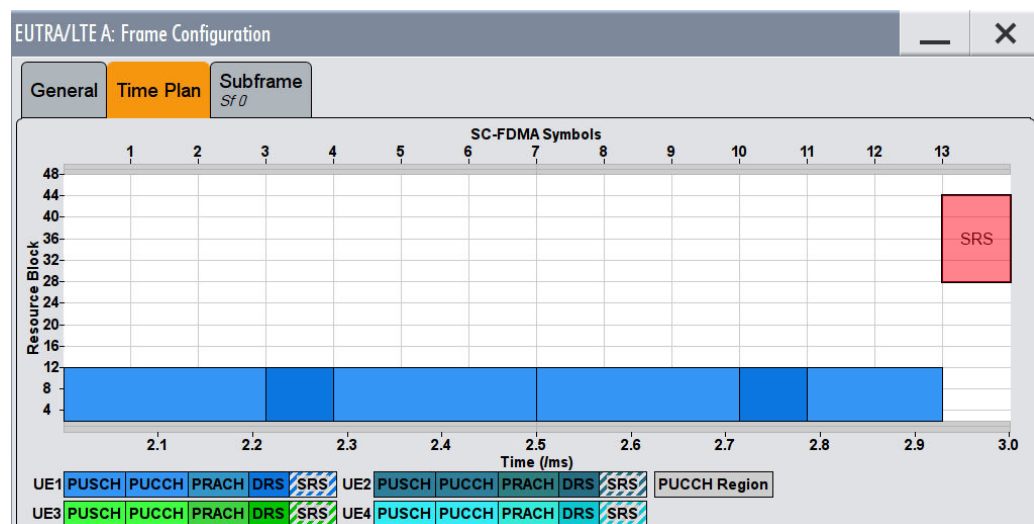

Fig. 4-2: No EVM can be measured for the SRS

In this case it is not reasonable to calculate an EVM and no SRS EVM value will be displayed for the corresponding subframe.

If the SRS subcarriers contain two DMRS symbols (or one DMRS and one PUSCH for "Pilot and Payload" channel estimation range) the SRS EVM can be measured (see figure 4-3).

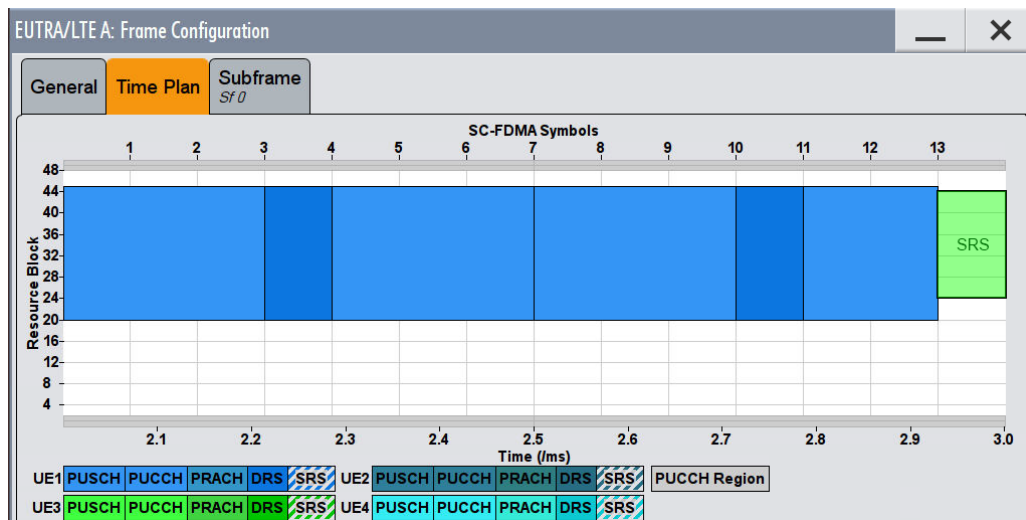

Fig. 4-3: The EVM of the complete SRS can be measured

The SRS allocation might cover subcarriers which partly fulfill the conditions mentioned above and partly do not. In this case the EVM value given in the Allocation Summary will be calculated based only on the subcarriers which fulfill the above requirements (see figure 4-4).

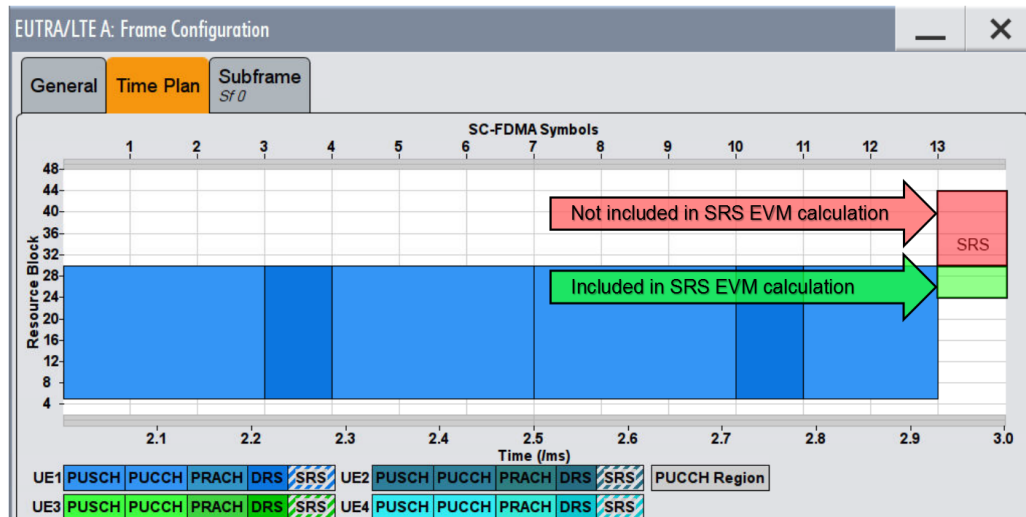

Fig. 4-4: The EVM for parts of the SRS can be measured

5 Configuration

LTE measurements require a special application on the R&S FPS, which you activate using the MODE key on the front panel.

When you activate a measurement channel in the LTE application, a measurement for the input signal is started automatically with the default configuration. The "LTE" menu is displayed and provides access to the most important configuration functions.



Automatic refresh of preview and visualization in dialog boxes after configuration changes

The R&S FPS supports you in finding the correct measurement settings quickly and easily - after each change in settings in dialog boxes, the preview and visualization areas are updated immediately and automatically to reflect the changes. Thus, you can see if the setting is appropriate or not before accepting the changes.



Unavailable hardkeys

Note that the SPAN, BW, TRACE, LINES and MKR FUNC keys have no contents and no function in the LTE application.

- [Configuration Overview](#).....39
- [Configuring I/Q Measurements](#).....41
- [Configuring Frequency Sweep Measurements](#).....73

5.1 Configuration Overview



Throughout the measurement channel configuration, an overview of the most important currently defined settings is provided in the "Overview". The "Overview" is displayed when you select the "Overview" icon, which is available at the bottom of all softkey menus.

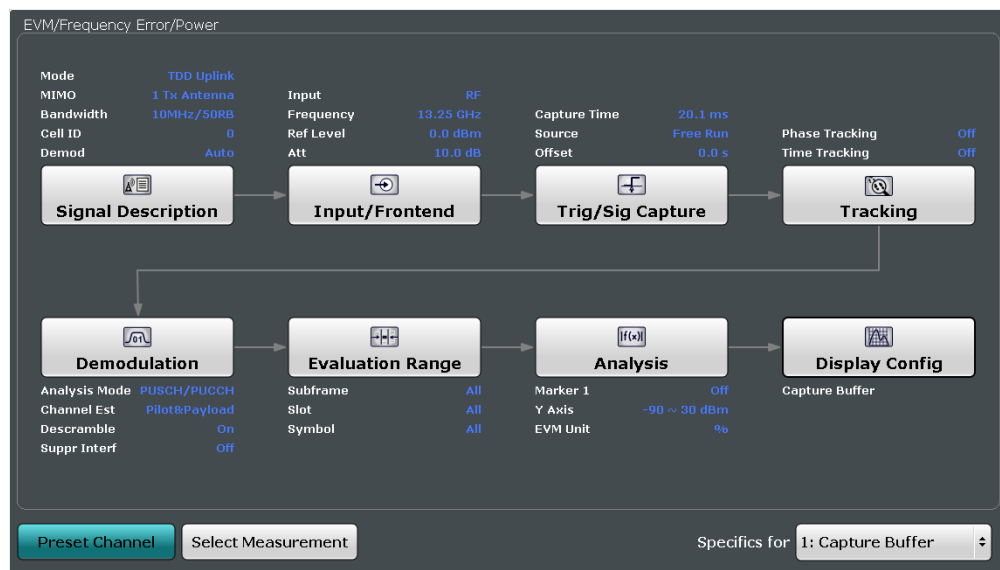

In addition to the main measurement settings, the "Overview" provides quick access to the main settings dialog boxes. The individual configuration steps are displayed in the order of the data flow. Thus, you can easily configure an entire measurement channel from input over processing to output and analysis by stepping through the dialog boxes as indicated in the "Overview".

In particular, the "Overview" provides quick access to the following configuration dialog boxes (listed in the recommended order of processing):

1. Signal Description
See [chapter 5.2.1, "Defining Signal Characteristics"](#), on page 42.
2. Input / Frontend
See [chapter 5.2.10, "Selecting the Input Source"](#), on page 63.
3. Trigger / Signal Capture
See [chapter 5.2.14, "Triggering Measurements"](#), on page 69
See [chapter 5.2.13, "Configuring the Data Capture"](#), on page 67
4. Tracking
See [chapter 5.2.15, "Tracking"](#), on page 70.
5. Demodulation
see [chapter 5.2.16, "Signal Demodulation"](#), on page 71.
6. Evaluation Range
See [chapter 6.2.1, "Evaluation Range"](#), on page 78.
7. Analysis
See [chapter 6, "Analysis"](#), on page 78.
8. Display Configuration
See [chapter 3, "Measurements and Result Displays"](#), on page 11.

In addition, the dialog box provides the "Select Measurement" button that serves as a shortcut to select the measurement type.

Note that the "Overview" dialog box for frequency sweep measurement is similar to that of the Spectrum mode.

For more information refer to the documentation of the R&S FPS.

To configure settings

- ▶ Select any button in the "Overview" to open the corresponding dialog box.
 - Select a setting in the channel bar (at the top of the measurement channel tab) to change a specific setting.

Preset Channel

Select the "Preset Channel" button in the lower lefthand corner of the "Overview" to restore all measurement settings **in the current channel** to their default values.

Note that the PRESET key restores the entire instrument to its default values and thus closes **all measurement channels** on the R&S FPS (except for the default Spectrum application channel)!

Remote command:

`SYSTem:PRESet:CHANnel[:EXECute]` on page 137

Specifics for

The measurement channel may contain several windows for different results. Thus, the settings indicated in the "Overview" and configured in the dialog boxes vary depending on the selected window.

Select an active window from the "Specifics for" selection list that is displayed in the "Overview" and in all window-specific configuration dialog boxes.

The "Overview" and dialog boxes are updated to indicate the settings for the selected window.

5.2 Configuring I/Q Measurements

• Defining Signal Characteristics.....	42
• Configuring MIMO Setups.....	46
• Configuring Subframes.....	47
• Defining Global Signal Characteristics.....	52
• Configuring the Demodulation Reference Signal.....	53
• Configuring the Sounding Reference Signal.....	55
• Defining the PUSCH Structure.....	58
• Defining the PUCCH Structure.....	59
• Defining the PRACH Structure.....	62
• Selecting the Input Source.....	63
• Defining the Frequency.....	64
• Defining Level Characteristics.....	65
• Configuring the Data Capture.....	67

- [Triggering Measurements](#)..... 69
- [Tracking](#)..... 70
- [Signal Demodulation](#)..... 71

5.2.1 Defining Signal Characteristics

The general signal characteristics contain settings to describe the general physical attributes of the signal. They are part of the "Signal Description" tab of the "Signal Description" dialog box.

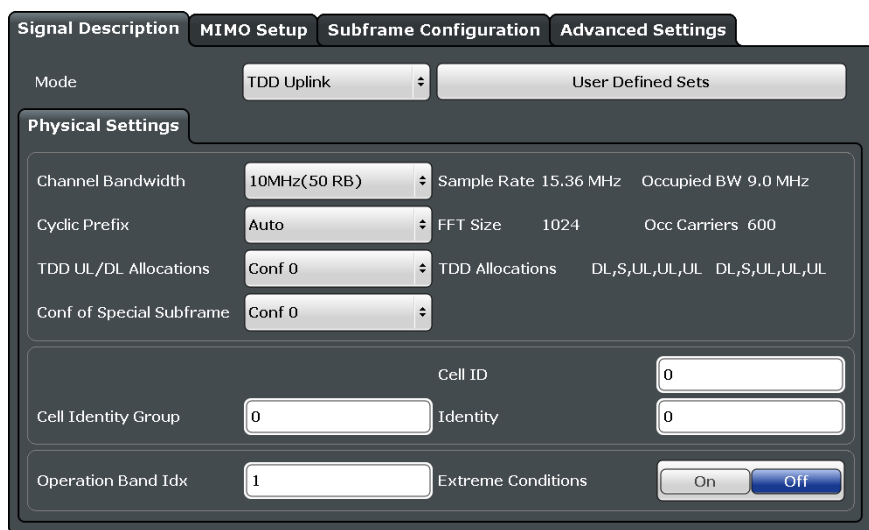

- [Selecting the LTE Mode](#)..... 42
- [Using Test Models](#)..... 43
- [Channel Bandwidth / Number of Resource Blocks](#)..... 43
- [Cyclic Prefix](#)..... 44
- [Configuring TDD Frames](#)..... 44
- [Configuring the Physical Layer Cell Identity](#)..... 45
- [Operating Band Index](#)..... 46
- [Extreme Conditions](#)..... 46

Selecting the LTE Mode

The standard defines the LTE mode you are testing.

The choices you have depend on the set of options you have installed.

- Option xxx-K100 enables testing of 3GPP LTE FDD signals on the downlink
- Option xxx-K101 enables testing of 3GPP LTE FDD signals on the uplink
- Option xxx-K102 enables testing of 3GPP LTE MIMO signals on the downlink
- Option xxx-K103 enables testing of 3GPP MIMO signals on the uplink
- Option xxx-K104 enables testing of 3GPP LTE TDD signals on the downlink
- Option xxx-K105 enables testing of 3GPP LTE TDD signals on the uplink

FDD and TDD are **duplexing** methods.

- FDD mode uses different frequencies for the uplink and the downlink.
- TDD mode uses the same frequency for the uplink and the downlink.

Downlink (DL) and Uplink (UL) describe the **transmission path**.

- Downlink is the transmission path from the base station to the user equipment. The physical layer mode for the downlink is always OFDMA.
- Uplink is the transmission path from the user equipment to the base station. The physical layer mode for the uplink is always SC-FDMA.

The application shows the currently selected LTE mode (including the bandwidth) in the channel bar.

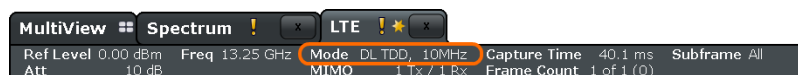

Remote command:

Link direction: `CONFigure[:LTE]:LDIRection` on page 138

Duplexing mode: `CONFigure[:LTE]:DUPLexing` on page 138

Using Test Models

Test models are descriptions of LTE signals that you can use for particular test scenarios.

The "Test Models" dialog box contains functionality to select, manage and create test models.

- "Specification"
 - The "Specification" tab contains predefined test models as defined by 3GPP. Predefined test models are supported in downlink mode.
- "User Defined"
 - The "User Defined" tab contains functionality to manage custom test models. Custom test models are supported in downlink and uplink mode. To create a custom test model, describe a signal as required and then save it via the "Test Models" dialog box. Here, you can also restore custom test models and delete ones you do not need anymore.

Predefined test models (E-TM)

In case of downlink signals, the 3GPP standard (TS 36.141) already defines several EUTRA test models (E-TM) for specific test scenarios. These test models are split into three main groups (E-TM1, E-TM2 and E-TM3) and are defined by the following characteristics.

- single antenna port, single code word, single layer and no precoding
- duration of one frame
- normal cyclic prefix
- localized virtual resource blocks, no intra-subframe hopping for PDSCH
- UE-specific reference signal not used

The data content of the physical channels and signals are defined in the 3GPP standard. Each E-TM is defined for all bandwidths defined in the standard (1.4 MHz / 3 MHz / 5 MHz / 10 MHz / 15 MHz / 20 MHz).

Channel Bandwidth / Number of Resource Blocks

Specifies the channel bandwidth and number of resource blocks (RB).

The channel bandwidth and number of resource blocks (RB) are interdependent. Currently, the LTE standard recommends six bandwidths (see table below).

The application also calculates the FFT size, sampling rate, occupied bandwidth and occupied carriers from the channel bandwidth. Those are read only.

Channel Bandwidth [MHz]	1.4	3	5	10	15	20
Number of Resource Blocks	6	15	25	50	75	100
Sample Rate [MHz]	1.92	3.84	7.68	15.36	30.72	30.72
FFT Size	128	256	512	1024	2048	2048

For more information about configuring aggregated carriers (for example for MC ACLR measurements) see "[Carrier Aggregation](#)" on page 76.

The application shows the currently selected LTE mode (including the bandwidth) in the channel bar.

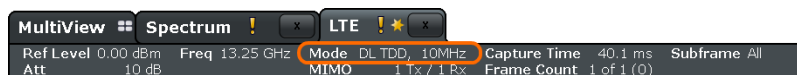

Remote command:

[CONFigure\[:LTE\]:UL\[:CC<cci>\]:BW](#) on page 138

Cyclic Prefix

The cyclic prefix serves as a guard interval between OFDM symbols to avoid interferences. The standard specifies two cyclic prefix modes with a different length each.

The cyclic prefix mode defines the number of OFDM symbols in a slot.

- Normal
A slot contains 7 OFDM symbols.
- Extended
A slot contains 6 OFDM symbols.
The extended cyclic prefix is able to cover larger cell sizes with higher delay spread of the radio channel.
- Auto
The application automatically detects the cyclic prefix mode in use.

Remote command:

[CONFigure\[:LTE\]:UL\[:CC<cci>\]:CYCPrefix](#) on page 139

Configuring TDD Frames

TDD frames contain both uplink and downlink information separated in time with every subframe being responsible for either uplink or downlink transmission. The standard specifies several subframe configurations or resource allocations for TDD systems.

TDD UL/DL Allocations

Selects the configuration of the subframes in a radio frame in TDD systems.

The UL/DL configuration (or allocation) defines the way each subframe is used: for uplink, downlink or if it is a special subframe. The standard specifies seven different configurations.

Configuration	Subframe Number and Usage									
	0	1	2	3	4	5	6	7	8	9
0	D	S	U	U	U	D	S	U	U	U
1	D	S	U	U	D	D	S	U	U	D
2	D	S	U	D	D	D	S	U	D	D
3	D	S	U	U	U	D	D	D	D	D
4	D	S	U	U	D	D	D	D	D	D
5	D	S	U	D	D	D	D	D	D	D
6	D	S	U	U	U	D	S	U	U	D

U = uplink

D = downlink

S = special subframe

Conf. of Special Subframe

In combination with the cyclic prefix, the special subframes serve as guard periods for switches from uplink to downlink. They contain three parts or fields.

- DwPTS
The DwPTS is the downlink part of the special subframe. It is used to transmit downlink data.
- GP
The guard period makes sure that there are no overlaps of up- and downlink signals during a switch.
- UpPTS
The UpPTS is the uplink part of the special subframe. It is used to transmit uplink data.

The length of the three fields is variable. This results in several possible configurations of the special subframe. The LTE standard defines 10 different configurations for the special subframe. However, configurations 8 and 9 only work for a normal cyclic prefix.

If you select configurations 8 or 9 using an extended cyclic prefix or automatic detection of the cyclic prefix, the application will show an error message.

Remote command:

Subframe: `CONFigure[:LTE]:UL[:CC<cci>]:TDD:UDConf` on page 140

Special subframe: `CONFigure[:LTE]:UL[:CC<cci>]:TDD:SPSC` on page 140

Configuring the Physical Layer Cell Identity

The cell ID, cell identity group and physical layer identity are interdependent parameters. In combination they are responsible for synchronization between network and user equipment.

The physical layer cell ID identifies a particular radio cell in the LTE network. The cell identities are divided into 168 unique cell identity groups. Each group consists of 3 physical layer identities. According to

$$N_{ID}^{cell} = 3 \cdot N_{ID}^{(1)} + N_{ID}^{(2)}$$

$N^{(1)}$ = cell identity group, {0...167}

$N^{(2)}$ = physical layer identity, {0...2}

there is a total of 504 different cell IDs.

If you change one of these three parameters, the application automatically updates the other two.

The Cell ID determines

- the reference signal grouping hopping pattern
- the reference signal sequence hopping
- the PUSCH demodulation reference signal pseudo-random sequence
- the cyclic shifts for PUCCH formats 1/1a/1b and sequences for PUCCH formats 2/2a/2b
- the pseudo-random sequence used for scrambling
- the pseudo-random sequence used for type 2 PUSCH frequency hopping

Remote command:

Cell ID: `CONFigure[:LTE]:UL[:CC<cci>]:PLC:CID` on page 139

Cell Identity Group: `CONFigure[:LTE]:UL[:CC<cci>]:PLC:CIDGroup` on page 140

Identity: `CONFigure[:LTE]:UL[:CC<cci>]:PLC:PLID` on page 140

Operating Band Index

Selects one of the 40 operating bands for spectrum flatness measurements as defined in TS 36.101.

The operating band defines the frequency band and the dedicated duplex mode.

Remote command:

`[SENSe][:LTE]:SFLatness:OBANd` on page 142

Extreme Conditions

Turns extreme conditions on and off.

If you turn the extreme conditions on, the software will modify the limit lines for the limit check of the spectral flatness measurement.

Remote command:

`[SENSe][:LTE]:SFLatness:ECONditions` on page 142

5.2.2 Configuring MIMO Setups

The MIMO Configuration contains settings to configure MIMO test setups.

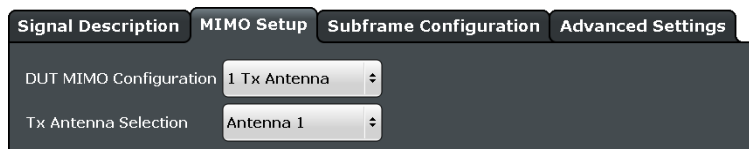

[MIMO Configuration](#)..... 46

MIMO Configuration

Selects the antenna configuration and test conditions for a MIMO system.

The MIMO **configuration** selects the number of transmit antennas for selected channels in the system.

In setups with multiple antennas, the **antenna selection** defines the antenna you'd like to test. Note that as soon as you have selected a transmission on more than one antenna for one of the channels, the corresponding number of antennas becomes available for testing.

Antenna 1	Tests antenna 1 only.
Antenna 2	Tests antenna 2 only.
Antenna 3	Tests antenna 3 only.
Antenna 4	Tests antenna 4 only.

Remote command:

[CONFigure\[:LTE\]:UL:MIMO:ASElection](#) on page 142

5.2.3 Configuring Subframes

An LTE frame consists of 10 subframes. Each individual subframe may have a different resource block configuration. This configuration is shown in the "Subframe Configuration Table".

The application supports two ways to determine the characteristics of each subframe.

- Automatic demodulation of the channel configuration and detection of the subframe characteristics.
In case of automatic demodulation, the contents of the table are determined according to the signal currently evaluated.
For more information see "[Auto Demodulation](#)" on page 48.
- Custom configuration of the configuration of each subframe.
In case of manual configuration, you can customize the table according to the signal that you expect. The signal is demodulated even if the signal does not fit the description in the table or, in case of [Physical Detection](#), only if the frame fits the description in the table.

Remote command:

Conf. subframes: [CONFigure\[:LTE\]:UL:CSUBframes](#) on page 143

Frame number offset

A frame number offset is also supported. The frame number offset assigns a number to the demodulated frame in order to identify it in a series of transmitted (and captured) frames. You can define this frame in the [Global Settings](#).

Remote command:

[CONFigure\[:LTE\]:UL:SFNO](#) on page 147

- [General Subframe Configuration](#)..... 48
- [Individual Subframe Configuration](#)..... 48
- [Enhanced Settings](#)..... 50

5.2.3.1 General Subframe Configuration

Auto Demodulation.....	48
Subframe Configuration Detection.....	48

Auto Demodulation

Turns automatic demodulation on and off.

If active, the R&S FPS automatically detects the characteristics of each subframe in the signal (resource allocation of the signal).

Two methods of detection are supported:

- Auto Demodulation, **DMRS Auto Detection (Off)**

This method automatically determines the characteristics for each subframe as shown in the [Subframe Configuration Table](#).

The table is populated accordingly.

- Subframe Configuration & DMRS

Auto Demodulation, **DMRS Auto Detection (On)**

This method automatically detects the PUSCH and SRS (i.e. no PUCCH can be detected).

To determine these characteristics, the software detects the CAZAC base parameters. Thus, the DMRS configuration parameters are not required for the synchronization and therefore are not available using this method.

Note however that it is not possible to derive the DMRS configuration parameters from the CAZAC base parameters so that the disabled DMRS configuration parameters do not reflect the current parameters used for the synchronization. Also note that it can happen that the software successfully synchronizes on non-3GPP signals without a warning.

Automatic demodulation is not available if the Suppressed Interference Synchronization is active.

Remote command:

[\[SENSe\] \[:LTE\] :UL:DEMod:ACON](#) on page 147

Subframe Configuration Detection

Turns the detection of the subframe configuration on and off.

Upon activation, the software compares the current demodulated LTE frame to the subframe configuration you have set. Only if the signal is consistent with the configuration, the software will further analyze the LTE frame.

If inactive, the software analyzes the signal even if it is not consistent with the current subframe configuration.

Subframe configuration detection is available if you are using a [Predefined](#) subframe configuration.

Remote command:

[\[SENSe\] \[:LTE\] :UL:FORMat:SCD](#) on page 147

5.2.3.2 Individual Subframe Configuration

The "Subframe Configuration Table" contains the characteristics for each subframe. The software supports a maximum uplink LTE frame size of 10 subframes. The sub-

frame number in the table depends on the number of "Configurable Subframes" that you have defined or that have been detected in case of automatic demodulation.

Subframe	Enable PUCCH	Enable PUSCH	Modulation	Enhanced Settings	Number of RBs	Offset RB	Conflict
0 (Not Us...)							
1 (Not Us...)							
2	Off	On	QPSK	...	10	2	
3	Off	On	QPSK	...	10	2	
4	Off	On	QPSK	...	10	2	
5 (Not Us...)							
6 (Not Us...)							

Each row of the table represents one subframe. If the fields in a row are unavailable for editing, the corresponding subframe is occupied by a downlink subframe or the special subframe (in TDD systems).

Subframe Number.....49
 Enable PUCCH..... 49
 Enable PUSCH..... 49
 Modulation.....49
 Enhanced Settings..... 50
 Number of RB..... 50
 Offset RB.....50

Subframe Number

Shows the number of a subframe.

Note that, depending on the TDD configuration, some subframes may not be available for editing. The R&S FPS labels those subframes "(not used)".

Enable PUCCH

Turns the PUCCH in the corresponding subframe on and off.

Remote command:

```
CONFigure[:LTE]:UL[:CC<cci>]:SUBFrame<subframe>:ALLoc:CONT
```

on page 143

Enable PUSCH

Turns the PUSCH in the corresponding subframe on and off.

If you turn on a PUSCH, "Modulation", "Number of RBs" and "Offset RB" become available.

Remote command:

```
CONFigure[:LTE]:UL[:CC<cci>]:SUBFrame<subframe>:ALLoc:CONT
```

on page 143

Modulation

Selects the modulation scheme for the corresponding PUSCH allocation.

The modulation scheme is either QPSK, 16QAM or 64QAM.

Remote command:

```
CONFigure[:LTE]:UL[:CC<cci>]:SUBFrame<subframe>:ALLoc:MODulation
```

on page 144

Enhanced Settings

Opens a dialog box to configure enhanced functionality for selected channels in each subframe.

For more information see [Enhanced Settings](#).

Number of RB

Sets the number of resource blocks the PUSCH allocation covers. The number of resource blocks defines the size or bandwidth of the PUSCH allocation.

Remote command:

```
CONFigure[:LTE]:UL[:CC<cci>]:SUBFrame<subframe>:ALLoc[:
CLUSter<cluster>]:RBCount on page 146
```

Offset RB

Sets the resource block at which the PUSCH allocation begins.

Make sure not to allocate PUSCH allocations into regions reserved for PUCCH allocations.

Remote command:

```
CONFigure[:LTE]:UL[:CC<cci>]:SUBFrame<subframe>:ALLoc[:
CLUSter<cluster>]:RBOffset on page 146
```

5.2.3.3 Enhanced Settings

The "Enhanced Settings" contain functionality to define enhanced characteristics for selected channels.

[Enhanced PUSCH Configuration](#)..... 50
[Enhanced Demodulation Reference Signal Configuration](#)..... 51
[Enhanced PUCCH Configuration](#)..... 51

Enhanced PUSCH Configuration

Configures the PUSCH in individual subframes.



Resource Allocation Type 1

Turns a clustered PUSCH allocation on and off. If on, a second row is added to the corresponding allocation. This second row represents the second cluster.

You can define the number of resource block and the offset resource block for each cluster. All other parameters (power, modulation etc.) are the same for both clusters.

Precoding Settings

If you are using a clustered PUSCH, you can also define the number of layers for any allocation and the codebook index.

The number of layers of an allocation in combination with the number of code words determines the layer mapping. The available number of layers depends on the number of transmission antennas. Thus, the maximum number of layers you can select is four.

The codebook index determines the precoding matrix. The available number of indices depends on the number of transmission antennas in use. The range is from 0 to 23.

Remote command:

```
CONFigure[:LTE]:UL[:CC<cci>]:SUBFrame<subframe>:ALLoc:RATO
```

on page 146

```
CONFigure[:LTE]:UL[:CC<cci>]:SUBFrame<subframe>:ALLoc:PRECoding:
```

CLMapping on page 144

```
CONFigure[:LTE]:UL[:CC<cci>]:SUBFrame<subframe>:ALLoc:PRECoding:
```

CBIndex on page 144

Enhanced Demodulation Reference Signal Configuration

Configures the Demodulation Reference Signal in individual subframes.

n(2)_DMRS	<input type="text" value="0"/>
Cyclic Shift Field	<input type="text" value="0"/>

n(2)_DMRS

Defines the part of the demodulation reference signal index that is part of the uplink scheduling assignment. Thus, this part of the index is valid for corresponding UE and subframe only.

The index applies when multiple shifts within a cell are used. It is used for the calculation of the DMRS sequence.

Cyclic Shift Field

If [Activate-DMRS-With OCC](#) is on, the "Cyclic Shift Field" becomes available to define the cyclic shift field.

The Cyclic Shift Field is signalled by the PDCCH downlink channel in DCI format 0 and 4. It selects n(2)_DMRS and the orthogonal sequence (OCC) for signals according to LTE release 10.

If the "Cyclic Shift Field" is off, the demodulation reference signal is configured by the n(2)_DMRS parameter.

Remote command:

```
CONFigure[:LTE]:UL[:CC<cci>]:SUBFrame<subframe>:ALLoc:PUSCh:
```

NDMRs on page 146

```
CONFigure[:LTE]:UL[:CC<cci>]:SUBFrame<subframe>:ALLoc:PUSCh:
```

CSField on page 145

Enhanced PUCCH Configuration

Configures the PUSCH in individual subframes.

Format	<input type="text" value="F1"/>
n_PUCCH	<input type="text" value="0"/>

n_PUCCH

Defines the n_PUCCH parameter for the selected subframe.

Available only if you have selected "Per Subframe" for the [N_PUCCH](#).

PUCCH Format

Selects the PUCCH format for the selected subframe.

Available only if you have selected "Per Subframe" for the [Format](#).

Remote command:

n_PUCCH: [CONFigure\[:LTE\]:UL\[:CC<cci>\]:SUBFrame<subframe>:ALLoc:PUCCh:NPAr](#) on page 145

Format: [CONFigure\[:LTE\]:UL\[:CC<cci>\]:SUBFrame<subframe>:ALLoc:PUCh:FORMat](#) on page 144

5.2.4 Defining Global Signal Characteristics

The global settings contain settings that apply to the complete signal.

The global signal settings are part of the "Advanced Settings" tab of the "Signal Description" dialog box.

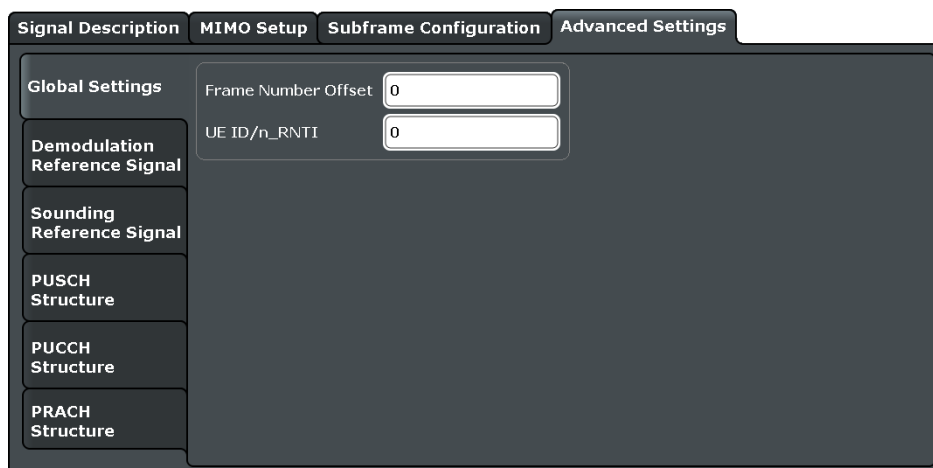

Frame Number Offset	52
UE ID/n_RNTI	52

Frame Number Offset

Defines a frame number offset for the analyzed frame.

The frame number offset assigns a number to the demodulated frame in order to identify it in a series of transmitted (and captured) frames.

Remote command:

[CONFigure\[:LTE\]:UL:SFNO](#) on page 147

UE ID/n_RNTI

Sets the radio network temporary identifier (RNTI) of the UE.

Remote command:

[CONFigure\[:LTE\]:UL:UEID](#) on page 148

5.2.5 Configuring the Demodulation Reference Signal

The demodulation reference signal (DRS) settings contain settings that define the physical attributes and structure of the demodulation reference signal. This reference signal helps to demodulate the PUSCH.

The demodulation reference signal settings are part of the "Advanced Settings" tab of the "Signal Description" dialog box.

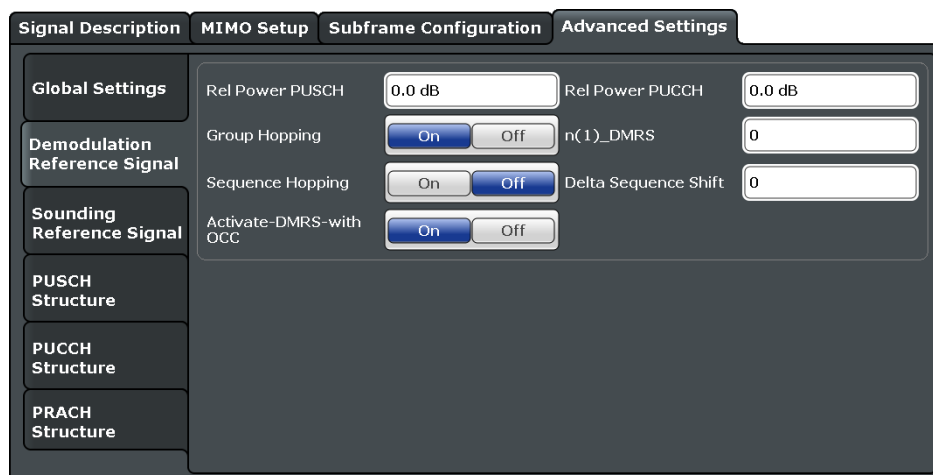

Relative Power PUSCH..... 53
 Group Hopping..... 53
 Sequence Hopping..... 54
 Relative Power PUCCH..... 54
 n(1)_DMRS..... 54
 Delta Sequence Shift..... 54
 Activate-DMRS-With OCC..... 54

Relative Power PUSCH

Defines the power of the DMRS relative to the power level of the PUSCH allocation in the corresponding subframe (P_{DMRS_Offset}).

The effective power level of the DMRS depends on the allocation of the subframe and is calculated as follows.

$$P_{DMRS} = P_{UE} + P_{PUSCH} + P_{DMRS_Offset}$$

The relative power of the DMRS is applied to all subframes.

The power of the PUSCH (P_{PUSCH}) may be different in each subframe.

Remote command:

`CONFigure[:LTE]:UL[:CC<cci>]:DRS[:PUSCh]:POWER` on page 149

Group Hopping

Turns group hopping for the demodulation reference signal on and off.

The group hopping pattern is based on 17 hopping patterns and 30 sequence shift patterns. It is generated by a pseudo-random sequence generator.

If on, PUSCH and PUCCH use the same group hopping pattern.

Remote command:

`CONFigure[:LTE]:UL[:CC<cci>]:DRS:GRPHopping` on page 149

Sequence Hopping

Turns sequence hopping for the uplink demodulation reference signal on and off.

Sequence hopping is generated by a pseudo-random sequence generator.

Remote command:

`CONFigure[:LTE]:UL[:CC<cci>]:DRS:SEQHopping` on page 149

Relative Power PUCCH

Defines the power of the DMRS relative to the power level of the PUCCH allocation in the corresponding subframe (P_{DMRS_Offset}).

The effective power level of the DMRS depends on the allocation of the subframe and is calculated as follows.

$$P_{DMRS} = P_{UE} + P_{PUCCH} + P_{DMRS_Offset}$$

The relative power of the DMRS is applied to all subframes.

The power of the PUCCH (P_{PUCCH}) may be different in each subframe.

Remote command:

`CONFigure[:LTE]:UL[:CC<cci>]:DRS:PUCCh:POWer` on page 149

n(1)_DMRS

Defines the part of the demodulation reference signal index that is broadcast. It is valid for the whole cell.

The index applies when multiple shifts within a cell are used. It is used for the calculation of the DMRS sequence.

The `n_DMRS` parameter can be found in 3GPP TS36.211 V8.5.0, 5.5.2.1.1 Reference signal sequence.

Remote command:

`CONFigure[:LTE]:UL[:CC<cci>]:DRS:NDMRs` on page 149

Delta Sequence Shift

Defines the delta sequence shift Δ_{SS} .

The standard defines a sequence shift pattern f_{ss} for the PUCCH. The corresponding sequence shift pattern for the PUSCH is a function of f_{ss}^{PUCCH} and the delta sequence shift.

For more information refer to 3GPP TS 36.211, chapter 5.5.1.3 "Group Hopping".

Remote command:

`CONFigure[:LTE]:UL[:CC<cci>]:DRS:DSSHift` on page 148

Activate-DMRS-With OCC

Turns the configuration of the demodulation reference signal on a subframe basis via the "Cyclic Shift Field" on and off.

If on, the "Cyclic Shift Field" becomes available. Otherwise, the demodulation reference signal is configured by the n(2)_DMRS parameter.

Note that this parameter is automatically turned on if at least one of the physical channels uses more than one antenna.

For more information see [Enhanced Settings](#) and [MIMO Configuration](#).

Remote command:

CONFigure[:LTE]:UL[:CC<cci>]:DRS:AOC

5.2.6 Configuring the Sounding Reference Signal

The sounding reference signal (SRS) settings contain settings that define the physical attributes and structure of the sounding reference signal.

The sounding reference signal settings are part of the "Advanced Settings" tab of the "Signal Description" dialog box.

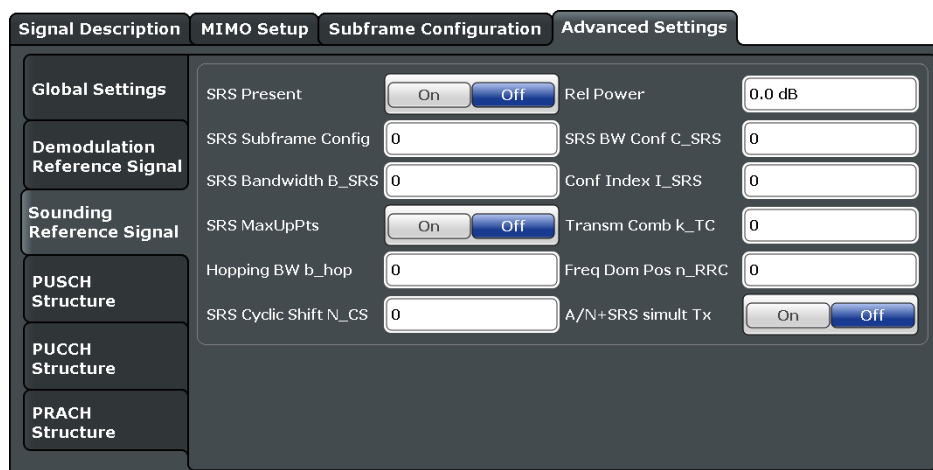

- Present..... 55
- SRS Subframe Conf..... 56
- SRS MaxUpPts..... 56
- SRS Bandwidth B_SRS..... 56
- Hopping BW b_hop..... 56
- SRS Cyclic Shift N_CS..... 56
- SRS Rel Power..... 57
- SRS BW Conf. C_SRS..... 57
- Conf. Index I_SRS..... 57
- Transm. Comb. k_TC..... 57
- Freq. Domain Pos. n_RRC..... 57
- A/N + SRS Simultaneous TX..... 58

Present

Includes or excludes the sounding reference signal (SRS) from the test setup.

Remote command:

CONFigure[:LTE]:UL:SRS:STAT

SRS Subframe Conf.

Defines the subframe configuration of the SRS.

The subframe configuration of the SRS is specific to a cell. The UE sends a shortened PUCCH/PUSCH in these subframes, regardless of whether the UE is configured to send an SRS in the corresponding subframe or not.

Remote command:

[CONFigure\[:LTE\]:UL:SRS:SUConfig](#) on page 153

SRS MaxUpPts

Turns the parameter `srs_MaxUpPts` on and off.

`srs_MaxUpPts` controls the SRS transmission in the `UpPTS` field in TDD systems. If on, the SRS is transmitted in a frequency range of the `UpPTS` field that does not overlap with resources reserved for PRACH preamble 4 transmissions.

To avoid an overlap, the number of SRS resource blocks otherwise determined by `C_SRS` and `B_SRS` is reconfigured.

Remote command:

[CONFigure\[:LTE\]:UL:SRS:MUPT](#) on page 152

SRS Bandwidth `B_SRS`

Defines the parameter B_{SRS} .

B_{SRS} is a UE specific parameter that defines the bandwidth of the SRS. The SRS either spans the entire frequency bandwidth or uses frequency hopping when several narrowband SRS cover the same total bandwidth.

The standard defines up to four bandwidths for the SRS. The most narrow SRS bandwidth ($B_{SRS} = 3$) spans four resource blocks and is available for all channel bandwidths. The other three values of B_{SRS} define more wideband SRS bandwidths. Their availability depends on the channel bandwidth.

The availability of SRS bandwidths additionally depends on the bandwidth configuration of the SRS (C_{SRS}).

For more information refer to 3GPP TS 36.211, chapter 5.5.3.2 "Mapping to Physical Resources" for the Sounding Reference Signal.

Remote command:

[CONFigure\[:LTE\]:UL:SRS:BSRS](#) on page 151

Hopping BW `b_hop`

Defines the parameter b_{hop} .

b_{hop} is a UE specific parameter that defines the frequency hopping bandwidth. SRS frequency hopping is active if $b_{hop} < B_{SRS}$.

For more information refer to 3GPP TS 36.211, chapter 5.5.3.2 "Mapping to Physical Resources" for the Sounding Reference Signal.

Remote command:

[CONFigure\[:LTE\]:UL:SRS:BHOP](#) on page 150

SRS Cyclic Shift `N_CS`

Defines the cyclic shift (n_{CS}) used for the generation of the SRS CAZAC sequence.

Because the different shifts of the same Zadoff-Chu sequence are orthogonal to each other, applying different SRS cyclic shifts can be used to schedule different UE to simultaneously transmit their SRS.

Remote command:

[CONFigure\[:LTE\]:UL:SRS:CYCS](#) on page 151

SRS Rel Power

Defines the power of the SRS relative to the power of the corresponding UE ($P_{\text{SRS_Offset}}$).

The effective power level of the SRS is calculated as follows.

$$P_{\text{SRS}} = P_{\text{UE}} + P_{\text{SRS_Offset}}$$

The relative power of the SRS is applied to all subframes.

Remote command:

[CONFigure\[:LTE\]:UL:SRS:POWer](#) on page 152

SRS BW Conf. C_SRS

Defines the bandwidth configuration of the SRS.

The bandwidth configuration is a cell specific parameter that, in combination with the SRS bandwidth and the channel bandwidth, defines the length of the sounding reference signal sequence. For more information on the calculation refer to 3GPP TS 36.211 chapter 5.5.3 "Sounding Reference Signal".

Remote command:

[CONFigure\[:LTE\]:UL:SRS:CSRS](#) on page 151

Conf. Index I_SRS

Defines the configuration index of the SRS.

The configuration index I_{SRS} is a cell specific parameter that determines the SRS periodicity (T_{SRS}) and the SRS subframe offset (T_{offset}). The effects of the configuration index on T_{SRS} and T_{offset} depends on the duplexing mode.

For more information refer to 3GPP TS 36.213, Table 8.2-1 (FDD) and 8.2-2 (TDD).

Remote command:

[CONFigure\[:LTE\]:UL:SRS:ISRS](#) on page 151

Transm. Comb. k_TC

Defines the transmission comb k_{TC} .

The transmission comb. is a UE specific parameter. For more information refer to 3GPP TS 36.211, chapter 5.5.3.2 "Mapping to Physical Resources" for the Sounding Reference Signal.

Remote command:

[CONFigure\[:LTE\]:UL:SRS:TRComb](#) on page 153

Freq. Domain Pos. n_RRC

Defines the parameter n_{RRC} .

n_{RRC} is a UE specific parameter and determines the starting physical resource block of the SRS transmission.

For more information refer to 3GPP TS 36.211, chapter 5.5.3.2 "Mapping to Physical Resources" for the Sounding Reference Signal.

Remote command:

[CONFigure\[:LTE\]:UL:SRS:NRRC](#) on page 152

A/N + SRS Simultaneous TX

Turns simultaneous transmission of the Sounding Reference Signal (SRS) and ACK/NACK messages (via PUCCH) on and off.

By turning the parameter on, you allow for simultaneous transmission of PUCCH and SRS in the same subframe.

If off, the SRS not transmitted in the subframe for which you have configured simultaneous transmission of PUCCH and SRS.

Note that simultaneous transmission of SRS and PUCCH is available only if the PUCCH format is either 1, 1a, 1b or 3. The other PUCCH formats contain CQI reports which are not transmitted with the SRS.

Remote command:

[CONFigure\[:LTE\]:UL:SRS:ANST](#) on page 150

5.2.7 Defining the PUSCH Structure

The PUSCH structure settings contain settings that describe the physical attributes and structure of the PUSCH.

The PUSCH structure settings are part of the "Advanced Settings" tab of the "Signal Description" dialog box.

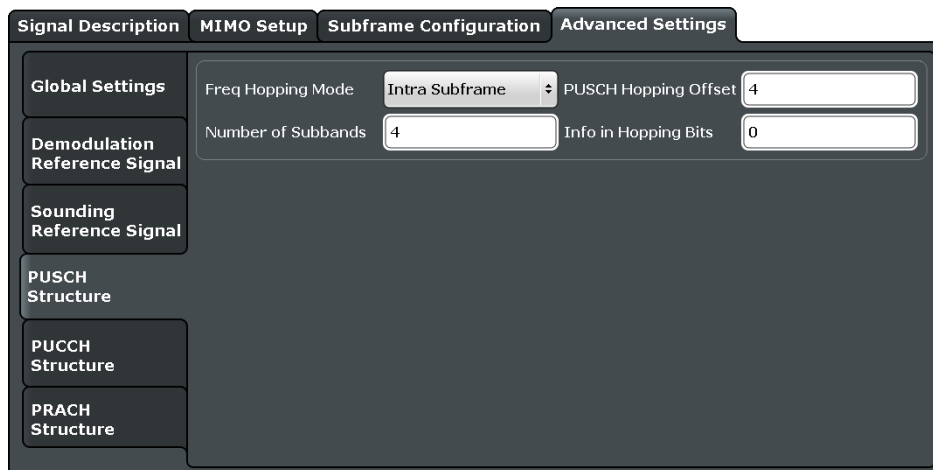

[Frequency Hopping Mode](#)..... 58
[Number of Subbands](#)..... 59
[PUSCH Hopping Offset](#)..... 59
[Info. in Hopping Bits](#)..... 59

Frequency Hopping Mode

Selects the frequency hopping mode of the PUSCH.

Several hopping modes are supported.

- None
No frequency hopping.
- Inter Subframe Hopping
PUSCH changes the frequency from one subframe to another.
- Intra Subframe Hopping
PUSCH also changes the frequency within a subframe.

Remote command:

[CONFigure\[:LTE\]:UL\[:CC<cci>\]:PUSCh:FHMode](#) on page 153

Number of Subbands

Defines the number of subbands reserved for PUSCH.

For more information refer to 3GPP TS 36.211, chapter 5.5.3.2 "Mapping to Physical Resources" for the Sounding Reference Signal.

Remote command:

[CONFigure\[:LTE\]:UL\[:CC<cci>\]:PUSCh:NOSM](#) on page 154

PUSCH Hopping Offset

Defines the PUSCH Hopping Offset N_{RB}^{HO} .

The PUSCH Hopping Offset determines the first physical resource block and the maximum number of physical resource blocks available for PUSCH transmission if PUSCH frequency hopping is active.

Remote command:

[CONFigure\[:LTE\]:UL\[:CC<cci>\]:PUSCh:FHOOffset](#) on page 154

Info. in Hopping Bits

Defines the information available in the hopping bits according to the PDCCH DCI format 0 hopping bit definition.

The information in the hopping bits determines whether type 1 or type 2 hopping is used in the subframe and, in case of type 1, additionally determines the exact hopping function to use.

For more information on PUSCH frequency hopping refer to 3GPP TS36.213.

Remote command:

[CONFigure\[:LTE\]:UL\[:CC<cci>\]:PUSCh:FHOP:IIHB](#) on page 154

5.2.8 Defining the PUCCH Structure

The PUCCH structure settings contain settings that describe the physical attributes and structure of the PUCCH.

The PUCCH structure settings are part of the "Advanced Settings" tab of the "Signal Description" dialog box.

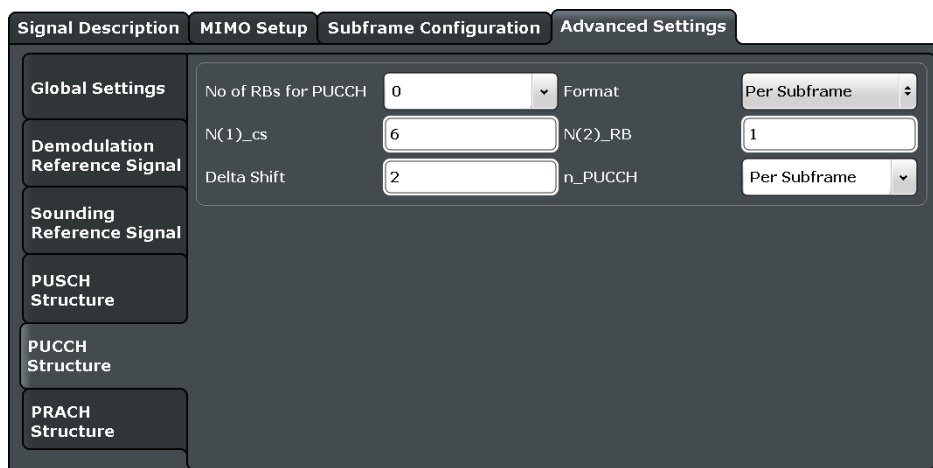

No. of RBs for PUCCH.....60
 N(1)_cs.....60
 Delta Shift.....61
 Format.....61
 N(2)_RB.....61
 N_PUCCH.....61

No. of RBs for PUCCH

Defines the number of resource blocks reserved for PUCCH.

The resource blocks for PUCCH are always allocated at the edges of the LTE spectrum.

In case of an even number of PUCCH resource blocks, half of the available PUCCH resource blocks is allocated on the lower, the other half on the upper edge of the LTE spectrum (outermost resource blocks).

In case of an odd number of PUCCH resource blocks, the number of resource blocks on the lower edge is one resource block larger than the number of resource blocks on the upper edge of the LTE spectrum.

If you select the "Auto" menu item, the application automatically detects the number of RBs.

Remote command:

[CONFigure\[:LTE\]:UL:PUCCh:NORB](#) on page 156

N(1)_cs

Defines the number of cyclic shifts used for PUCCH format 1/1a/1b in a resource block used for a combination of the formats 1/1a/1b and 2/2a/2b.

Only one resource block per slot can support a combination of the PUCCH formats 1/1a/1b and 2/2a/2b.

The number of cyclic shifts available for PUCCH format 2/2a/2b N(2)_cs in a block with combination of PUCCH formats is calculated as follows.

$$N(2)_cs = 12 - N(1)_cs - 2$$

For more information refer to 3GPP TS36.211, chapter 5.4 "Physical Uplink Control Channel".

Remote command:

[CONFigure\[:LTE\]:UL:PUCCh:N1CS](#) on page 155

Delta Shift

Defines the delta shift parameter.

The delta shift is the difference between two adjacent PUCCH resource indices with the same orthogonal cover sequence (OC).

It determines the number of available sequences in a resource block that can be used for PUCCH formats 1/1a/1b.

For more information refer to 3GPP TS36.211, chapter 5.4 "Physical Uplink Control Channel".

Remote command:

[CONFigure\[:LTE\]:UL:PUCCh:DEShift](#) on page 154

Format

Selects the format of the PUCCH.

You can define the PUCCH format for all subframes or define the PUCCH format for each subframe individually.

- F1, F1a, F1b, F2, F2a, F2b, F3
Selects the PUCCH format globally for every subframe.
- Per Subframe
You can select the PUCCH format for each subframe separately in the [Enhanced Settings](#) of the "Subframe Configuration".

Note that formats F2a and F2b are only supported for normal cyclic prefix length.

For more information refer to 3GPP TS36.211, table 5.4-1 "Supported PUCCH Formats".

Remote command:

[CONFigure\[:LTE\]:UL:PUCCh:FORMat](#) on page 155

N(2)_RB

Defines bandwidth in terms of resource blocks that are reserved for PUCCH formats 2/2a/2b transmission in each subframe.

Since there can be only one resource block per slot that supports a combination of the PUCCH formats 1/1a/1b and 2/2a/2b, the number of resource block(s) per slot available for PUCCH format 1/1a/1b is determined by N(2)_RB.

For more information refer to 3GPP TS36.211, chapter 5.4 "Physical Uplink Control Channel".

Remote command:

[CONFigure\[:LTE\]:UL:PUCCh:N2RB](#) on page 155

N_PUCCH

Defines the resource index for PUCCH format 1/1a/1b respectively 2/2a/2b.

It is also possible to define N_{PUCCH} on a subframe level by selecting the "Per Subframe" menu item. For more information see [chapter 5.2.3, "Configuring Subframes"](#), on page 47.

Remote command:

`CONFigure[:LTE]:UL:PUCCh:NPAr` on page 156

5.2.9 Defining the PRACH Structure

The PRACH structure settings contain settings that describe the physical attributes and structure of the PUCCH.

The PRACH structure settings are part of the "Advanced Settings" tab of the "Signal Description" dialog box.

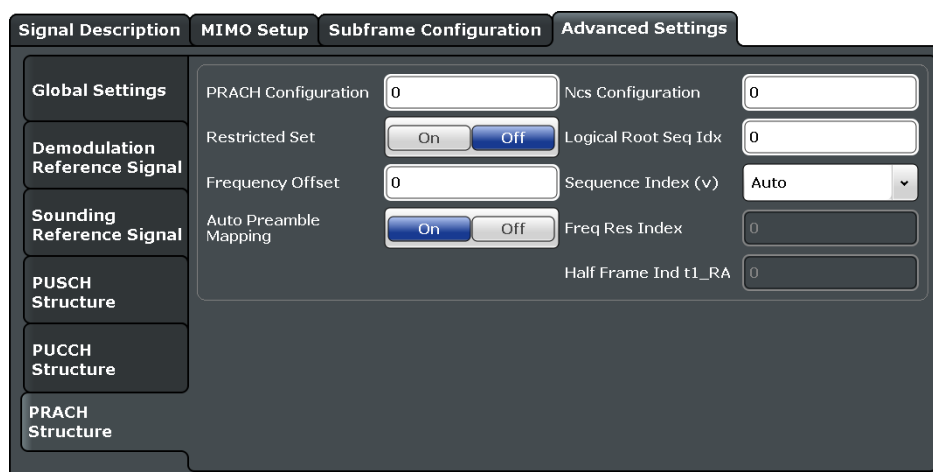

[PRACH Configuration](#)..... 62
[Restricted Set](#).....62
[Frequency Offset](#).....63
[PRACH Preamble Mapping](#)..... 63
[Ncs Conf](#)..... 63
[Logical Root Sequ. Idx](#)..... 63
[Sequence Index \(v\)](#)..... 63

PRACH Configuration

Sets the PRACH configuration index as defined in the 3GPP TS 36.211, i.e. defines the subframes in which random access preamble transmission is allowed.

The preamble format is automatically derived form the PRACH Configuration.

Remote command:

`CONFigure[:LTE]:UL:PRACH:CONF` on page 157

Restricted Set

Selects whether a restricted preamble set (high speed mode) or the unrestricted preamble set (normal mode) will be used.

Remote command:

`CONFigure[:LTE]:UL:PRACH:RSET` on page 158

Frequency Offset

For preamble formats 0-3, sets the PRACH Frequency Offset as defined in the 3GPP TS 36.211, i.e. determines the first physical resource block available for PRACH expressed as a physical resource block number.

Remote command:

`CONFigure[:LTE]:UL:PRACH:FOFFset` on page 157

PRACH Preamble Mapping

The frequency resource index f_{RA} and the half frame indicator $t1_{RA}$ are necessary to clearly specify the physical resource mapping of the PRACH in case a PRACH configuration index has more than one mapping alternative.

If you turn on the "Auto Preamble Mapping", the software automatically detects f_{RA} and $t1_{RA}$.

The values for both parameters are defined in table '5.7.1-4: Frame structure type 2 random access preamble mapping in time and frequency' (3GPP TS 36.211 v10.2.0).

The frequency resource index and half frame indicator are available in TDD mode.

Remote command:

`CONFigure[:LTE]:UL:PRACH:APM` on page 157

`CONFigure[:LTE]:UL:PRACH:FRINDEX` on page 157

`CONFigure[:LTE]:UL:PRACH:HFINDicator` on page 158

Ncs Conf

Selects the Ncs configuration, i.e. determines the Ncs value set according to TS 36.211, table 5.7.2.-2 and 5.7.2-3.

Remote command:

`CONFigure[:LTE]:UL:PRACH:NCSC` on page 158

Logical Root Sequ. Idx

Selects the logical root sequence index.

The logical root sequence index is used to generate preamble sequences. It is provided by higher layers.

Remote command:

`CONFigure[:LTE]:UL:PRACH:RSEQ` on page 158

Sequence Index (v)

Defines the sequence index (v).

The sequence index controls which of the 64 preambles available in a cell is used.

If you select the "Auto" menu item, the software automatically selects the required sequence index.

Remote command:

`CONFigure[:LTE]:UL:PRACH:SINDEX` on page 158

5.2.10 Selecting the Input Source

- [RF Input](#)..... 64

5.2.10.1 RF Input

Functions to configure the RF input described elsewhere:

- "Input Coupling" on page 67
- "Impedance" on page 67

YIG-Preselector.....64

YIG-Preselector

Activates or deactivates the YIG-preselector, if available on the R&S FPS.

An internal YIG-preselector at the input of the R&S FPS ensures that image frequencies are rejected. However, this is only possible for a restricted bandwidth. In order to use the maximum bandwidth for signal analysis you can deactivate the YIG-preselector at the input of the R&S FPS, which may lead to image-frequency display.

Note that the YIG-preselector is active only on frequencies greater than 8 GHz. Therefore, switching the YIG-preselector on or off has no effect if the frequency is below that value.

Remote command:

INPut:FILTer:YIG[:STATe] on page 159

5.2.11 Defining the Frequency

Frequency settings define the frequency characteristics of the signal at the RF input. They are part of the "Frequency" tab of the "Signal Characteristics" dialog box.

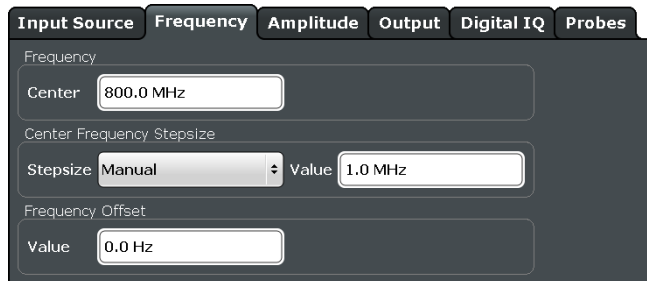

Defining the Signal Frequency..... 64

Defining the Signal Frequency

For measurements with an RF input source, you have to match the **center frequency** of the analyzer to the frequency of the signal.

The available frequency range depends on the hardware configuration of the analyzer you are using.

In addition to the frequency itself, you can also define a frequency stepsize. The frequency stepsize defines the extent of a frequency change if you change it for example with the rotary knob. Define the stepsize in two ways.

- = Center
One frequency step corresponds to the current center frequency.
- Manual

Define a any stepsize you need.

Remote command:

Center frequency: [SENSe]:FREQuency:CENTer[:CC<cci>] on page 160

Frequency stepsize: [SENSe:]FREQuency:CENTer:STEP on page 161

Frequency offset: [SENSe]:FREQuency:CENTer[:CC<cci>]:OFFSet on page 161

5.2.12 Defining Level Characteristics

Amplitude settings define the expected level characteristics of the signal at the RF input.

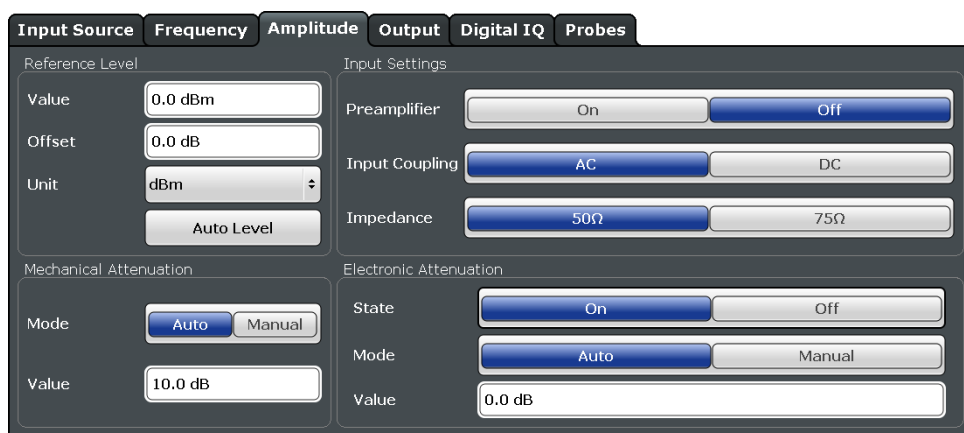

Defining a Reference Level..... 65

Attenuating the Signal..... 66

Preamplifier (option B22/B24)..... 67

Input Coupling..... 67

Impedance..... 67

Defining a Reference Level

The reference level is the power level the analyzer expects at the RF input. Keep in mind that the power level at the RF input is the peak envelope power in case of signals with a high crest factor like LTE.

To get the best dynamic range, you have to set the reference level as low as possible. At the same time, make sure that the maximum signal level does not exceed the reference level. If it does, it will overload the A/D converter, regardless of the signal power. Measurement results may deteriorate (e.g. EVM). This applies especially for measurements with more than one active channel near the one you are trying to measure (± 6 MHz).

Note that the signal level at the A/D converter may be stronger than the level the application displays, depending on the current resolution bandwidth. This is because the resolution bandwidths are implemented digitally after the A/D converter.

You can specify the reference level in several **units** and define an arithmetic **level offset**. A level offset is useful if the signal is attenuated or amplified before it is fed into the analyzer. All displayed power level results will be shifted by this value. Note however, that the reference value ignores the level offset. Thus, it is still mandatory to define the actual power level that the analyzer has to handle as the reference level. You can also use **automatic detection** of the reference level with the "Auto Level" function.

If active, the application measures and sets the reference level to its ideal value.

Automatic level detection also optimizes RF attenuation.

The application shows the current reference level (including RF and external attenuation) in the channel bar.



Remote command:

Manual: `DISPlay[:WINDOW<n>]:TRACe<t>:Y[:SCALE]:RLEVel` on page 163

Automatic: `[SENSE:]ADJust:LEVel` on page 166

Offset: `DISPlay[:WINDOW<n>]:TRACe<t>:Y[:SCALE]:RLEVel:OFFSet` on page 163

Unit: `CALCulate<n>:UNIT:POWer` on page 162

Attenuating the Signal

Attenuation of the signal may become necessary if you have to reduce the power of the signal that you have applied. Power reduction is necessary, for example, to prevent an overload of the input mixer.

The LTE measurement application provides several attenuation modes.

- **Mechanical** (or RF) attenuation is always available. The mechanical attenuator controls attenuation at the RF input.
- It is also possible to equip the R&S FPS with the optional **electronic** attenuator. Note that the frequency range may not exceed the specification of the electronic attenuator for it to work.
For both methods, the application provides **automatic** detection of the ideal attenuation level. Alternatively, you can define the attenuation level **manually**. The range is from 0 dB to 79 dB (RF attenuation) or 30 dB (electronic attenuation) in 1 dB steps.

For more information on attenuating the signal see the manual of the R&S FPS.

The application shows the attenuation level (mechanical and electronic) in the channel bar.

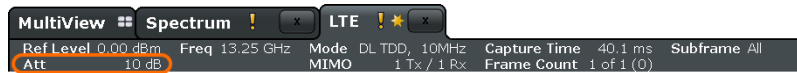

Remote command:

RF attenuation: [INPut:ATTenuation](#) on page 163

RF attenuation: [INPut:ATTenuation:AUTO](#) on page 164

Electronic attenuation: [INPut<n>:EATT:STATE](#) on page 166

Electronic attenuation: [INPut<n>:EATT:AUTO](#) on page 165

Electronic attenuation: [INPut<n>:EATT](#) on page 165

Preamplifier (option B22/B24)

Switches the preamplifier on and off. If activated, the input signal is amplified by 20 dB.

If option R&S FPS-B22 is installed, the preamplifier is only active below 7 GHz.

If option R&S FPS-B24 is installed, the preamplifier is active for all frequencies.

Remote command:

[INPut:GAIN:STATE](#) on page 164

Input Coupling

The RF input of the R&S FPS can be coupled by alternating current (AC) or direct current (DC).

AC coupling blocks any DC voltage from the input signal. This is the default setting to prevent damage to the instrument. Very low frequencies in the input signal may be distorted.

However, some specifications require DC coupling. In this case, you must protect the instrument from damaging DC input voltages manually. For details, refer to the data sheet.

Remote command:

[INPut:COUPling](#) on page 164

Impedance

The reference impedance for the measured levels of the R&S FPS can be set to 50 Ω or 75 Ω .

75 Ω should be selected if the 50 Ω input impedance is transformed to a higher impedance using a 75 Ω adapter of the RAZ type (= 25 Ω in series to the input impedance of the instrument). The correction value in this case is 1.76 dB = 10 log (75 Ω /50 Ω).

This value also affects the unit conversion.

Remote command:

[INPut:IMPedance](#) on page 165

5.2.13 Configuring the Data Capture

The data capture settings contain settings that control the data capture.

The data capture settings are part of the "Signal Capture" tab of the "Trigger/Signal Capture" dialog box.

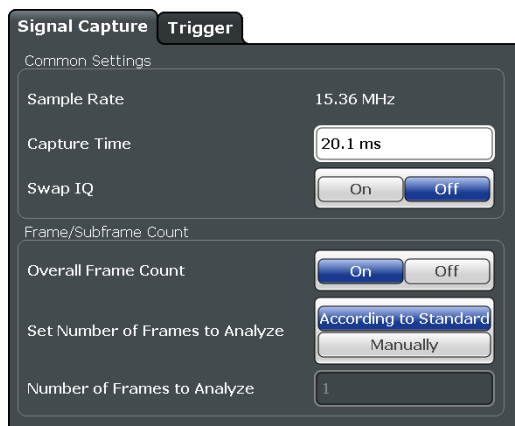

Capture Time..... 68

Swap I/Q..... 68

Overall Frame Count..... 68

Auto According to Standard..... 69

Number of Frames to Analyze..... 69

Single Subframe Mode.....69

Capture Time

Defines the capture time.

The capture time corresponds to the time of one sweep. Hence, it defines the amount of data the application captures during one sweep.

By default, the application captures 20.1 ms of data to make sure that at least one complete LTE frame is captured in one sweep.

The application shows the current capture time in the channel bar.

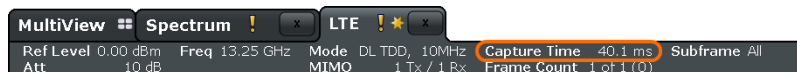

Remote command:

```
[SENSe] :SWEp:TIME on page 168
```

Swap I/Q

Swaps the real (I branch) and the imaginary (Q branch) parts of the signal.

Remote command:

```
[SENSe] :SWAPiq on page 168
```

Overall Frame Count

Turns the manual selection of the number of frames to capture (and analyze) on and off.

If the overall frame count is active, you can define a particular number of frames to capture and analyze. The measurement runs until all required frames have been analyzed, even if it takes more than one sweep. The results are an average of the captured frames.

If the overall frame count is inactive, the R&S FPS analyzes all complete LTE frames currently in the capture buffer.

The application shows the current frame count in the channel bar.

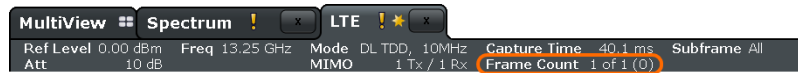

Remote command:

[\[SENSe\] \[:LTE\] :FRAMe:COUNT:STATE](#) on page 167

Auto According to Standard

Turns automatic selection of the number of frames to capture and analyze on and off.

If active, the R&S FPS evaluates the number of frames as defined for EVM tests in the LTE standard.

If inactive, you can set the number of frames you want to analyze.

This parameter is not available if the overall frame count is inactive.

Remote command:

[\[SENSe\] \[:LTE\] :FRAMe:COUNT:AUTO](#) on page 167

Number of Frames to Analyze

Sets the number of frames that you want to capture and analyze.

If the number of frames you have set last longer than a single sweep, the R&S FPS continues the measurement until all frames have been captured.

The parameter is read only if

- the overall frame count is inactive,
- the data is captured [according to the standard](#).

Remote command:

[\[SENSe\] \[:LTE\] :FRAMe:COUNT](#) on page 167

Single Subframe Mode

Turns the evaluation of a single subframe only on and off.

Evaluating a single subframe only improves the measurement speed. For successful synchronization, the subframe must be located within the captured data (= 1.2 ms).

You can make sure that this is the case by using, for example, an external frame trigger signal.

For maximum measurement speed, the application turns off [Auto According to Standard](#) and sets the [Number of Frames to Analyze](#) to 1. These settings prevent the application from capturing data more than once for a single run measurement.

Remote command:

[\[SENSe:\] \[LTE:\] FRAMe:SSUBframe](#) on page 168

5.2.14 Triggering Measurements

The trigger functionality of the LTE measurement application is the same as that of the R&S FPS. For a comprehensive description of the available trigger settings see the documentation of the R&S FPS.

Note that some trigger sources available in Spectrum mode are not available in the LTE application. Note also that the Preview and Gate functionality are only available for frequency sweep measurements (ACLR and SEM).



Gated frequency sweep measurements

The application automatically selects the correct gate settings (delay and length) according to the [TDD configuration](#).

The trigger settings are part of the "Trigger" tab of the "Trigger/Signal Capture" dialog box.

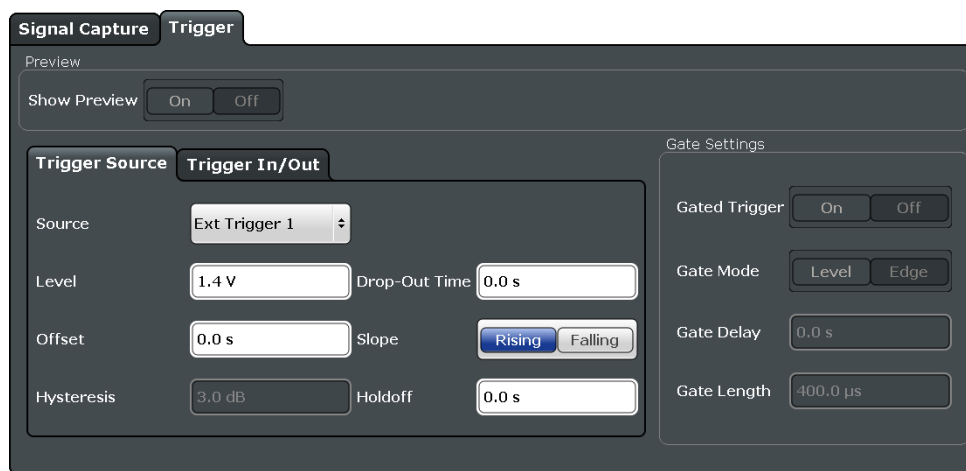

For more information on triggering measurements see the documentation of the R&S FPS.

5.2.15 Tracking

The tracking settings contain settings that compensate for various common measurement errors that may occur.

[Phase](#)..... 70
[Timing](#)..... 71

Phase

Specifies whether or not the measurement results should be compensated for common phase error. When phase compensation is used, the measurement results will be compensated for phase error on a per-symbol basis.

- "Off" Phase tracking is not applied.
- "Pilot Only" Only the reference signal is used for the estimation of the phase error.
- "Pilot and Payload" Both reference signal and payload resource elements are used for the estimation of the phase error.

Remote command:

[\[:SENSe\] \[:LTE\] :UL:TRACking:PHASe](#) on page 173

Timing

Specifies whether or not the measurement results should be compensated for timing error. When timing compensation is used, the measurement results will be compensated for timing error on a per-symbol basis.

Remote command:

[SENSe] [:LTE]:UL:TRACking:TIME on page 173

5.2.16 Signal Demodulation

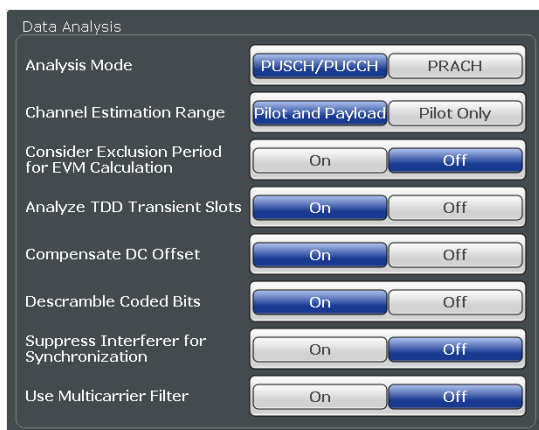

Analysis Mode.....71
 Channel Estimation Range.....71
 EVM with Exclusion Period.....72
 Analyze TDD Transient Slots.....72
 Compensate DC Offset.....72
 Scrambling of Coded Bits.....72
 Suppressed Interference Synchronization.....73
 Multicarrier Filter.....73

Analysis Mode

Selects the channel analysis mode.

You can select from "PUSCH/PUCCH" mode and "PRACH" mode.

PUSCH/PUCCH mode analyzes the PUSCH and PUCCH. This is the default.

PRACH mode analyzes the PRACH only. In PRACH analysis mode no subframe or slot selection is available. Instead you can select a particular preamble that the results are shown for. Note that PRACH analysis mode does not support all result displays.

Remote command:

[SENSe] [:LTE]:UL:DEMod:MODE on page 171

Channel Estimation Range

Selects the method for channel estimation.

You can select if only the pilot symbols are used to perform channel estimation or if both pilot and payload carriers are used.

Remote command:

[\[SENSe\] \[:LTE\]:UL:DEMod:CESTimation](#) on page 171

EVM with Exclusion Period

Turns exclusion periods for EVM measurements as defined in 3GPP TS 36.521 on and off.

The exclusion period affects the PUSCH data EVM of the first and last symbol.

The software automatically determines the length of the exclusion period according to 3GPP TS 36.521-1.

The exclusion period has no effect on the EVM vs Carrier and EVM vs Symbol x Carrier result displays.

Remote command:

[\[SENSe\] \[:LTE\]:UL:DEMod:EEPeriod](#) on page 171

Analyze TDD Transient Slots

Includes or excludes the transient slots present after a switch from downlink to uplink in the analysis.

If on, the transient slots are not included in the measurement.

Remote command:

[\[SENSe\] \[:LTE\]:UL:DEMod:ATTSlots](#) on page 170

Compensate DC Offset

Turns DC offset compensation when calculating measurement results on and off.

According to 3GPP TS 36.101 (Annex F.4), the R&S FPS removes the carrier leakage (I/Q origin offset) from the evaluated signal before it calculates the EVM and in-band emissions.

Remote command:

[\[SENSe\] \[:LTE\]:UL:DEMod:CDCOffset](#) on page 171

Scrambling of Coded Bits

Turns the scrambling of coded bits for the PUSCH on and off.

The scrambling of coded bits affects the bitstream results.

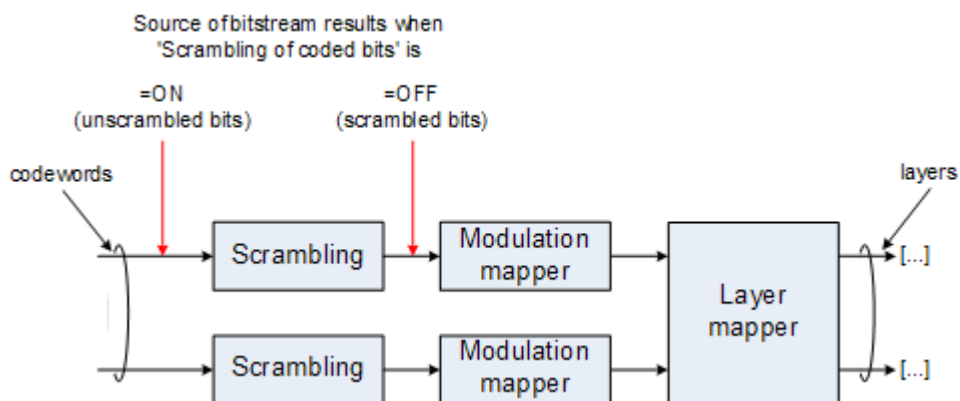

Fig. 5-1: Source for bitstream results if scrambling for coded bits is on and off

Remote command:

[\[SENSe\] \[:LTE\] :UL:DEMod:CBSCrambling](#) on page 172

Suppressed Interference Synchronization

Turns suppressed interference synchronization on and off.

If active, the synchronization on signals containing more than one user equipment (UE) is more robust. Additionally, the EVM is lower in case the UEs have different frequency offsets. Note that Auto Demodulation is not supported in this synchronization mode and the EVM may be higher in case only one UE is present in the signal.

Remote command:

[\[SENSe\] \[:LTE\] :UL:DEMod:SISync](#) on page 172

Multicarrier Filter

Turns the suppression of interference of neighboring carriers on and off.

Remote command:

[\[SENSe\] \[:LTE\] :UL:DEMod:MCFilter](#) on page 172

5.3 Configuring Frequency Sweep Measurements

After starting one of the frequency sweep measurements, the application automatically loads the configuration required by measurements according to the 3GPP standard: the spectral mask as defined in the 3GPP standard for SEM measurements and the channel configuration defined in the standard for the ACLR measurement.

If you need a different measurement configuration, you can change all parameters as required. Except for the dialog box described below, the measurement configuration menus for the frequency sweep measurements are the same as in the Spectrum application.

Please refer to the User Manual of the R&S FPS for a detailed description on how to configure ACLR and SEM measurements.

- [ACLR Signal Description](#).....74
- [SEM Signal Description](#)..... 74
- [MC ACLR Signal Description](#)..... 75

5.3.1 ACLR Signal Description

The signal description for ACLR measurements contains settings to describe general physical characteristics of the signal you are measuring.

- ▶ Press the MEAS CONFIG key.
- ▶ Press the "Signal Description" softkey.
The application opens the "Signal Description" dialog box.

For more information on the LTE Mode, Test Model and Channel Bandwidth see "[Selecting the LTE Mode](#)" on page 42, "[Using Test Models](#)" on page 43 and "[Channel Bandwidth / Number of Resource Blocks](#)" on page 43.

- [Assumed Adjacent Channel Carrier](#).....74

Assumed Adjacent Channel Carrier

Selects the assumed adjacent channel carrier for the ACLR measurement.

The supported types are EUTRA of same bandwidth, 1.28 Mcps UTRA, 3.84 Mcps UTRA and 7.68 Mcps UTRA.

Note that not all combinations of LTE Channel Bandwidth settings and Assumed Adj. Channel Carrier settings are defined in the 3GPP standard.

Remote command:

`[SENSe]:POWer:ACHannel:AACHannel` on page 175

5.3.2 SEM Signal Description

The signal description for SEM measurements contains settings to describe general physical characteristics of the signal you are measuring.

- ▶ Press the MEAS CONFIG key.
- ▶ Press the "Signal Description" softkey.
The application opens the "Signal Description" dialog box.

For more information on the LTE Mode, Test Model, Channel Bandwidth and Cyclic Prefix see "[Selecting the LTE Mode](#)" on page 42, "[Using Test Models](#)" on page 43, "[Channel Bandwidth / Number of Resource Blocks](#)" on page 43 and "[Cyclic Prefix](#)" on page 44.

- [SEM Requirement](#).....75

SEM Requirement

Selects the type of spectrum emission mask used for the Out of Band emission measurement.

The software supports general and specific (additional) spectrum emission masks. The specific spectrum emission masks contain additional SEM requirements. The additional requirements masks to use for the measurement depend on the network signaled value "NS_03", "NS_04", "NS_06" or "NS_07".

If "NS_06" or "NS_07" is indicated in the cell, use SEM requirement "NS_06_07".

Remote command:

[SENSe]:POWER:SEM:UL:REquirement on page 175

5.3.3 MC ACLR Signal Description

The signal description for MC ACLR measurements contain settings to describe general physical characteristics of the signal you are measuring.

▶ Press the MEAS CONFIG key.

▶ Press the "Signal Description" softkey.

The application opens the "Signal Description" dialog box.

You can configure the characteristics of the carriers in the "Carrier Configuration" tab.

Note: the "Carrier Configuration" button in the "Physical Settings" tab also opens the "Carrier Configuration" tab.

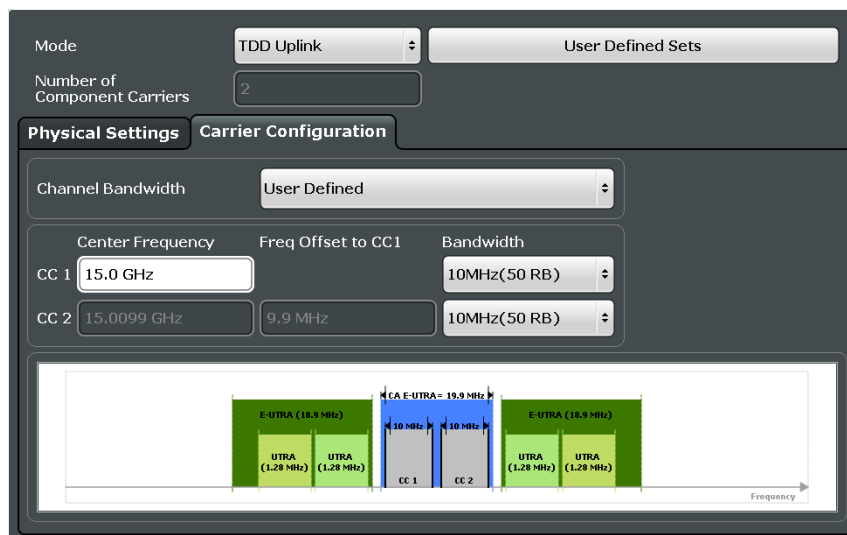

For more information on the LTE Mode, Test Model, Channel Bandwidth and Cyclic Prefix see "Selecting the LTE Mode" on page 42, "Using Test Models" on page 43, "Channel Bandwidth / Number of Resource Blocks" on page 43 and "Cyclic Prefix" on page 44.

Carrier Aggregation.....76

L Basic component carrier configuration	76
L Features of the MC ACLR measurement	77
L Remote commands to configure carrier aggregation	77

Carrier Aggregation

Carrier aggregation has been introduced in the LTE standard to increase the bandwidth. In those systems, several carriers can be used to transmit a signal. Each carrier usually has one of the [channel bandwidths](#) defined by 3GPP.

The R&S FPS features several measurements that support contiguous and non-contiguous intra-band carrier aggregation (the carriers are in the same frequency band).

- Time Alignment Error (downlink)
- Time Alignment Error (uplink)
- Transmit On/Off Power (downlink)
- Cumulative ACLR (downlink, non-contiguous intra-band carrier aggregation)
- Multi Carrier ACLR (downlink, non-contiguous intra-band carrier aggregation)
- Multi Carrier ACLR (uplink, contiguous intra-band carrier aggregation)
- SEM (downlink, non-contiguous intra-band carrier aggregation)
- SEM (uplink, contiguous intra-band carrier aggregation)

The way to configure these measurements is similar (but not identical, the differences are indicated below).

- ["Basic component carrier configuration"](#) on page 76
- ["Features of the MC ACLR measurement"](#) on page 77
- ["Remote commands to configure carrier aggregation"](#) on page 77

Basic component carrier configuration ← Carrier Aggregation

The number of component carriers (CCs) you can select depends on the measurement.

- Time Alignment Error: up to 2 CCs
- Multi-carrier ACLR: 2 CCs (fix value)
- SEM: up to 2 CCs

The **center frequency** defines the carrier frequency of the carriers, each with a certain **bandwidth** that you can select from the corresponding dropdown menu. For all component carriers, the application also shows the **frequency offset** relative to the center frequency of the first carrier.

Note that the application automatically calculates the frequency and offset of the second (or subsequent) carrier according to the 3GPP specification.

Note that the actual measurement frequency differs from the two carrier frequencies: the application calculates that frequency based on the carrier frequencies. It is somewhere in between the carrier frequencies. The measurement frequency is displayed at the bottom of the diagram area.

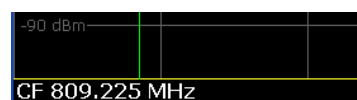

Selecting the **channel bandwidths** of each carrier is possible in two ways.

- Predefined bandwidth combinations
 - Select a typical combination of channel bandwidths from the dropdown menu.

This way, you just have to define the center frequency of the first carrier. The application calculates the rest of the frequency characteristics.

- User Defined
 Select "User Defined" from the dropdown menu to test a system with channel bandwidths not in the list of predefined combinations.
 When you select a user defined combination, you can select the channel bandwidth for each carrier from the "Bandwidth" dropdown menus.

When the defined carrier configuration is not supported by the application, a corresponding error message is displayed. This may be the case, for example, if the carriers occupy a bandwidth that is too large.

Features of the MC ACLR measurement ← Carrier Aggregation

The diagram at the bottom of the dialog box represents the current configuration. When you change the bandwidth of a carrier (represented by blue bars), the application adjusts the bandwidth of the carriers in the diagram accordingly.

The characteristics of the neighboring channels in the MC ACLR measurement are defined in 3GPP 36.251 (represented by green bars).

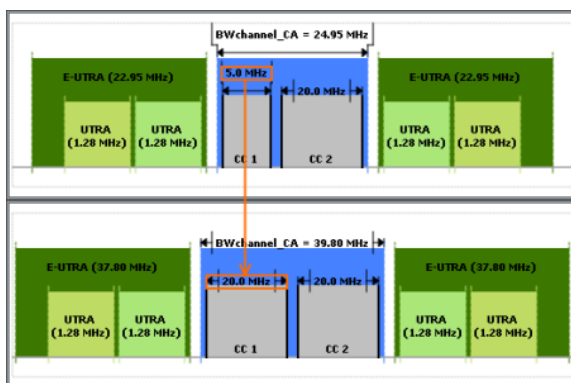

Remote commands to configure carrier aggregation ← Carrier Aggregation

- Remote command:
- Number of carriers: `CONFigure:NOCC` on page 174
- Carrier frequency: `[SENSe]:FREQuency:CENTer[:CC<cci>]` on page 160
- Measurement frequency: `SENSe:FREQuency:CENTer?`
- Offset: `[SENSe]:FREQuency:CENTer[:CC<cci>]:OFFSet` on page 161
- Channel bandwidth: `CONFigure[:LTE]:UL:CABW` on page 174
- Channel bandwidth: `CONFigure[:LTE]:UL[:CC<cci>]:BW` on page 138

6 Analysis

- [Configuring Tables / Numerical Results](#).....78
- [Analyzing I/Q Measurements](#).....78
- [Analyzing Frequency Sweep Measurements](#).....84

6.1 Configuring Tables / Numerical Results

The application allows you to customize the number of columns for some numeric result displays, for example the Allocation Summary.

- ▶ Select a point somewhere in the header row of the table.

Sub-frame	Allocation ID	No of RBs	Rel Power [dB]	Modulation	Power per RE [dBm]	EVM [%]
-----------	---------------	-----------	----------------	------------	--------------------	---------

The application opens a dialog box to add or remove columns.

Displayed Columns

<input checked="" type="checkbox"/> Subframe	<input checked="" type="checkbox"/> Modulation
<input checked="" type="checkbox"/> Allocation ID	<input checked="" type="checkbox"/> Power per RE [dBm]
<input checked="" type="checkbox"/> No of RBs	<input checked="" type="checkbox"/> EVM [%]
<input checked="" type="checkbox"/> Rel Power [dB]	

6.2 Analyzing I/Q Measurements

- [Evaluation Range](#).....78
- [Scale](#).....81
- [Result Settings](#).....81
- [Markers](#).....83

6.2.1 Evaluation Range

The evaluation range defines the signal parts that are considered during signal analysis.

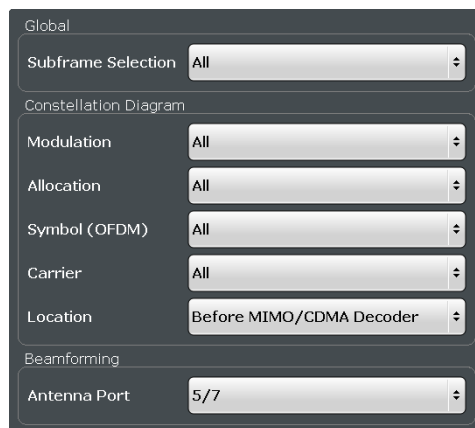

Subframe Selection.....79
 Slot Selection.....80
 Preamble Selection.....80
 Evaluation Range for the Constellation Diagram.....80

Subframe Selection

Selects a particular subframe whose results the application displays.

You can select a particular subframe for the following measurements.

Result Summary, EVM vs. Carrier, EVM vs. Symbol, EVM vs. Symbol x Carrier, Inband Emission, Channel Flatness, Spectrum Flatness SRS, Channel Group Delay, Spectrum Flatness Difference, Power vs Symbol x Carrier, Constellation Diagram, DFT Pre-coded Constellation, Allocation Summary, Bit Stream and Time Alignment. If ---All--- is selected, either the results from all subframes are displayed at once or a statistic is calculated over all analyzed subframes.

Selecting "All" either displays the results over all subframes or calculates a statistic over all subframes that have been analyzed.

Example: Subframe selection

If you select all subframes ("All"), the application shows three traces. One trace shows the subframe with the minimum level characteristics, the second trace shows the subframe with the maximum level characteristics and the third subframe shows the averaged level characteristics of all subframes.

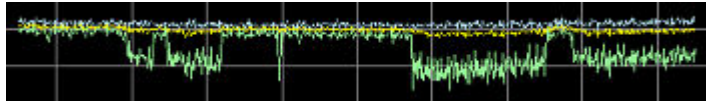

● 1 Avg ● 2 Min ● 3 Max

- PK: peak value
- AV: average value
- MI: minimum value

If you select a specific subframe, the application shows one trace. This trace contains the results for that subframe only.

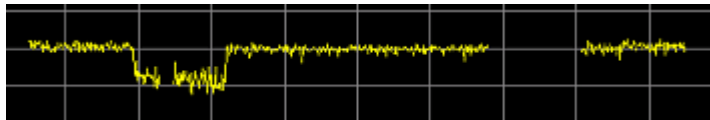

Remote command:

[\[SENSe\] \[:LTE\]:SUBFrame:SElect](#) on page 178

Slot Selection

Selects a particular slot whose measurement results you want to see.

You can select a particular slot for the following measurements.

Result Summary, EVM vs Carrier, EVM vs Symbol, EVM vs Symbol x Carrier, Inband Emission, Channel Flatness, Spectrum Flatness SRS, Channel Group Delay, Spectrum Flatness Difference, Power vs Symbol x Carrier, Constellation Diagram, DFT Pre-coded Constellation Diagram and Time Alignment.

In PRACH analysis mode, you can not select a particular slot.

Remote command:

[\[SENSe\] \[:LTE\]:SLOT:SElect](#) on page 177

Preamble Selection

Selects a particular preamble for measurements that analyze individual preambles.

Selecting preambles is available in PRACH analysis mode.

Remote command:

[\[SENSe\] \[:LTE\]:PREamble:SElect](#) on page 177

Evaluation Range for the Constellation Diagram

The "Evaluation Range" dialog box defines the type of constellation points that are displayed in the Constellation Diagram.

By default the application displays all constellation points of the data that have been evaluated. However, you can filter the results by several aspects.

- Modulation

- Filters the results to include only the selected type of modulation.
- Allocation
Filters the results to include only a particular type of allocation.
- Symbol
Filters the results to include only a particular OFDM symbol.
- Carrier
Filters the results to include only a particular subcarrier.

The result display is updated as soon as you make the changes.

Note that the constellation selection is applied to all windows in split screen mode if the windows contain constellation diagrams.

Remote command:

Modulation: `[SENSe][:LTE]:MODulation:SElect` on page 177

Allocation: `[SENSe][:LTE]:ALLocation:SElect` on page 176

Symbol: `[SENSe][:LTE]:SYMBOL:SElect` on page 178

Carrier: `[SENSe][:LTE]:CARRIER:SElect` on page 176

6.2.2 Scale

[Y-Axis Scale](#).....81

Y-Axis Scale

The y-axis scaling determines the vertical resolution of the measurement results. The scaling you select always applies to the currently active screen and the corresponding result display.

Usually, the best way to view the results is if they fit ideally in the diagram area in order to view the complete trace. This is the way the application scales the y-axis if you are using the **automatic scale** function.

But it may become necessary to see a more detailed version of the results. In that case, turn on fixed scaling for the y-axis by defining the **minimum** and **maximum** values displayed on the vertical axis. Possible values and units depend on the result display you want to adjust the scale of.

You can restore the default scale at any time with "Restore Scale".

Tip:

Alternatively, you can scale the windows in the "Auto Set" menu. In addition to scaling the window currently in focus ("Auto Scale Window"), there you can scale **all windows** at the same time ("Auto Scale All").

Remote command:

`DISPlay[:WINDow<n>]:TRACe<t>:Y[:SCALE]:AUTO ONCE` on page 179

`DISPlay[:WINDow<n>]:TRACe<t>:Y[:SCALE]:MAXimum` on page 179

`DISPlay[:WINDow<n>]:TRACe<t>:Y[:SCALE]:MINimum` on page 179

6.2.3 Result Settings

Result settings define the way certain measurement results are displayed.

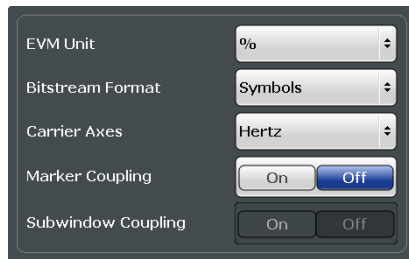

EVM Unit..... 82
 Bit Stream Format..... 82
 Carrier Axes..... 82
 Subwindow Coupling..... 83
 Marker Coupling..... 83

EVM Unit

Selects the unit for graphic and numerical EVM measurement results.

Possible units are dB and %.

Remote command:

[UNIT: EVM](#) on page 181

Bit Stream Format

Selects the way the bit stream is displayed.

The bit stream is either a stream of raw bits or of symbols. In case of the symbol format, the bits that belong to a symbol are shown as hexadecimal numbers with two digits.

Examples:

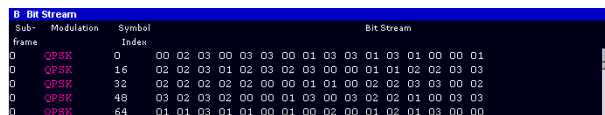

Fig. 6-1: Bit stream display in uplink application if the bit stream format is set to "symbols"

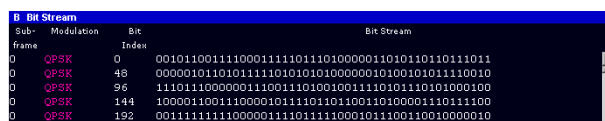

Fig. 6-2: Bit stream display in uplink application if the bit stream format is set to "bits"

Remote command:

[UNIT: BSTR](#) on page 180

Carrier Axes

Selects the scale of the x-axis for result displays that show results of OFDM subcarriers.

- X-axis shows the frequency of the subcarrier

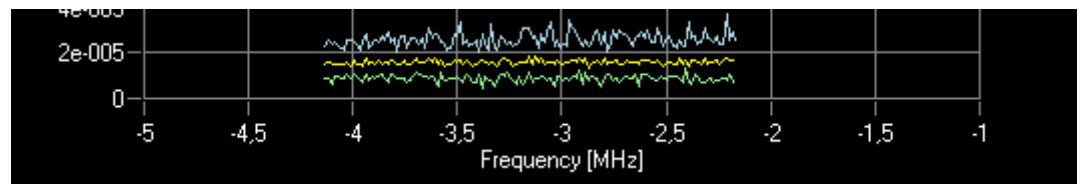

- X-axis shows the number of the subcarrier

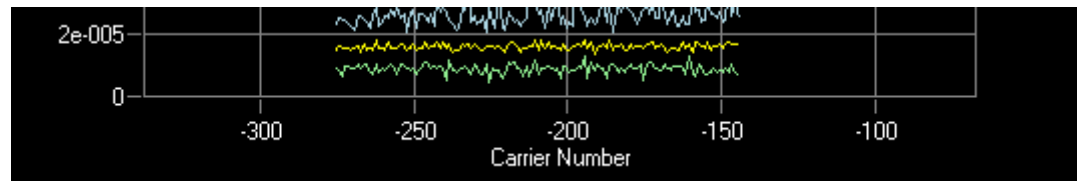

Remote command:

[UNIT:CAxEs](#) on page 180

Subwindow Coupling

Couples or decouples result display tabs (subwindows).

If the coupling is on and you select another tab in a result display, the application automatically selects the same tab for all result displays

Subwindow coupling is available for measurements with multiple data streams (MIMO).

Marker Coupling

Couples or decouples markers that are active in multiple result displays.

When you turn this feature on, the application moves the marker to its new position in all active result displays.

When you turn it off, you can move the markers in different result displays independent from each other.

Remote command:

[CALCulate:MARKer:COUpling](#) on page 180

6.2.4 Markers

Markers are available for most of the I/Q measurement result displays and for the frequency sweep measurements. The functionality (setting and positioning) is the same as in Spectrum mode.



Markers in result displays with a third aspect

In result displays that have a third dimension (EVM vs Symbol x Carrier etc.), you can position a marker on a particular symbol in a particular carrier.

When you activate a marker, you can select the symbol and carrier you want to position the marker on. Alternatively, you can define the marker position in the "Marker Configuration" dialog box, which is expanded accordingly.

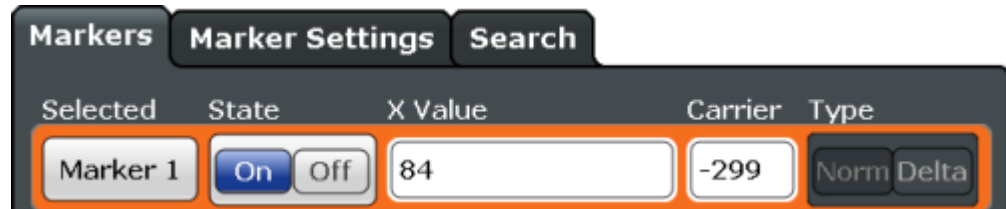

Fig. 6-3: Marker Configuration dialog, the "Carrier" field is only available for result displays with a third dimension.

For a comprehensive description of the marker functionality see the corresponding chapters in the documentation of the R&S FPS.

6.3 Analyzing Frequency Sweep Measurements

The LTE application supports the same functionality to analyze the results of frequency sweep measurements (Spectrum Emission mask and Adjacent Channel Leakage Ratio) as the R&S FPS base unit does for those measurements.

Please refer to the User Manual of the R&S FPS for a detailed description on how to analyze ACLR and SEM measurements.

7 Remote Control

The following remote control commands are required to configure and perform noise figure measurements in a remote environment. The R&S FPS must already be set up for remote operation in a network as described in the base unit manual.



Universal functionality

Note that basic tasks that are also performed in the base unit in the same way are not described here. For a description of such tasks, see the R&S FPS User Manual.

In particular, this includes:

- Managing Settings and Results, i.e. storing and loading settings and result data.
- Basic instrument configuration, e.g. checking the system configuration, customizing the screen layout, or configuring networks and remote operation.
- Using the common status registers (specific status registers for Pulse measurements are not used).

• Overview of Remote Command Suffixes	85
• Introduction	86
• Remote Commands to Select the LTE Application	91
• General Window Commands	94
• Working with Windows in the Display	95
• Performing Measurements	101
• Remote Commands to Read Trace Data	106
• Remote Commands to Read Numeric Results	117
• Remote Commands to Read Limit Check Results	127
• Remote Commands to Configure the Application	136
• Analysis	175

7.1 Overview of Remote Command Suffixes

The remote commands for the LTE Measurement application support the following suffixes.

Suffix	Description
<allocation>	Selects an allocation.
<analyzer>	No effect.
<antenna>	Selects an antenna for MIMO measurements.
<cluster>	Selects a cluster (uplink only).
<cwnum>	Selects a codeword.
<k>	Selects a limit line. Irrelevant for the LTE application.

Suffix	Description
<m>	Selects a marker.
<n>	Selects a measurement window.
<subframe>	Selects a subframe.
<t>	Selects a trace. Irrelevant for the LTE application.

7.2 Introduction

Commands are program messages that a controller (e.g. a PC) sends to the instrument or software. They operate its functions ('setting commands' or 'events') and request information ('query commands'). Some commands can only be used in one way, others work in two ways (setting and query). If not indicated otherwise, the commands can be used for settings and queries.

The syntax of a SCPI command consists of a header and, in most cases, one or more parameters. To use a command as a query, you have to append a question mark after the last header element, even if the command contains a parameter.

A header contains one or more keywords, separated by a colon. Header and parameters are separated by a "white space" (ASCII code 0 to 9, 11 to 32 decimal, e.g. blank). If there is more than one parameter for a command, these are separated by a comma from one another.

Only the most important characteristics that you need to know when working with SCPI commands are described here. For a more complete description, refer to the User Manual of the R&S FPS.



Remote command examples

Note that some remote command examples mentioned in this general introduction may not be supported by this particular application.

7.2.1 Conventions used in Descriptions

Note the following conventions used in the remote command descriptions:

- **Command usage**

If not specified otherwise, commands can be used both for setting and for querying parameters.

If a command can be used for setting or querying only, or if it initiates an event, the usage is stated explicitly.

- **Parameter usage**

If not specified otherwise, a parameter can be used to set a value and it is the result of a query.

Parameters required only for setting are indicated as **Setting parameters**.

Parameters required only to refine a query are indicated as **Query parameters**.

Parameters that are only returned as the result of a query are indicated as **Return values**.

- **Conformity**
Commands that are taken from the SCPI standard are indicated as **SCPI confirmed**. All commands used by the R&S FPS follow the SCPI syntax rules.
- **Asynchronous commands**
A command which does not automatically finish executing before the next command starts executing (overlapping command) is indicated as an **Asynchronous command**.
- **Reset values (*RST)**
Default parameter values that are used directly after resetting the instrument (*RST command) are indicated as ***RST** values, if available.
- **Default unit**
This is the unit used for numeric values if no other unit is provided with the parameter.
- **Manual operation**
If the result of a remote command can also be achieved in manual operation, a link to the description is inserted.

7.2.2 Long and Short Form

The keywords have a long and a short form. You can use either the long or the short form, but no other abbreviations of the keywords.

The short form is emphasized in upper case letters. Note however, that this emphasis only serves the purpose to distinguish the short from the long form in the manual. For the instrument, the case does not matter.

Example:

`SENSe:FREQuency:CENTer` is the same as `SENS:FREQ:CENT`.

7.2.3 Numeric Suffixes

Some keywords have a numeric suffix if the command can be applied to multiple instances of an object. In that case, the suffix selects a particular instance (e.g. a measurement window).

Numeric suffixes are indicated by angular brackets (<n>) next to the keyword.

If you don't quote a suffix for keywords that support one, a 1 is assumed.

Example:

`DISPlay[:WINDow<1...4>]:ZOOM:STATe` enables the zoom in a particular measurement window, selected by the suffix at `WINDow`.

`DISPlay:WINDow4:ZOOM:STATe ON` refers to window 4.

7.2.4 Optional Keywords

Some keywords are optional and are only part of the syntax because of SCPI compliance. You can include them in the header or not.

Note that if an optional keyword has a numeric suffix and you need to use the suffix, you have to include the optional keyword. Otherwise, the suffix of the missing keyword is assumed to be the value 1.

Optional keywords are emphasized with square brackets.

Example:

Without a numeric suffix in the optional keyword:

```
[SENSe:]FREQuency:CENTer is the same as FREQuency:CENTer
```

With a numeric suffix in the optional keyword:

```
DISPlay[:WINDow<1...4>]:ZOOM:STATe
```

DISPlay:ZOOM:STATe ON enables the zoom in window 1 (no suffix).

DISPlay:WINDow4:ZOOM:STATe ON enables the zoom in window 4.

7.2.5 Alternative Keywords

A vertical stroke indicates alternatives for a specific keyword. You can use both keywords to the same effect.

Example:

```
[SENSe:]BANDwidth|BWIDth[:RESolution]
```

In the short form without optional keywords, BAND 1MHZ would have the same effect as BWID 1MHZ.

7.2.6 SCPI Parameters

Many commands feature one or more parameters.

If a command supports more than one parameter, these are separated by a comma.

Example:

```
LAYout:ADD:WINDow Spectrum,LEFT,MTABLE
```

Parameters may have different forms of values.

- [Numeric Values](#).....89
- [Boolean](#).....89
- [Character Data](#).....90
- [Character Strings](#).....90
- [Block Data](#).....90

7.2.6.1 Numeric Values

Numeric values can be entered in any form, i.e. with sign, decimal point or exponent. In case of physical quantities, you can also add the unit. If the unit is missing, the command uses the basic unit.

Example:

with unit: `SENSe:FREQuency:CENTer 1GHZ`

without unit: `SENSe:FREQuency:CENTer 1E9` would also set a frequency of 1 GHz.

Values exceeding the resolution of the instrument are rounded up or down.

If the number you have entered is not supported (e.g. in case of discrete steps), the command returns an error.

Instead of a number, you can also set numeric values with a text parameter in special cases.

- **MIN/MAX**
Defines the minimum or maximum numeric value that is supported.
- **DEF**
Defines the default value.
- **UP/DOWN**
Increases or decreases the numeric value by one step. The step size depends on the setting. In some cases you can customize the step size with a corresponding command.

Querying numeric values

When you query numeric values, the system returns a number. In case of physical quantities, it applies the basic unit (e.g. Hz in case of frequencies). The number of digits after the decimal point depends on the type of numeric value.

Example:

Setting: `SENSe:FREQuency:CENTer 1GHZ`

Query: `SENSe:FREQuency:CENTer?` would return `1E9`

In some cases, numeric values may be returned as text.

- **INF/NINF**
Infinity or negative infinity. Represents the numeric values 9.9E37 or -9.9E37.
- **NAN**
Not a number. Represents the numeric value 9.91E37. NAN is returned in case of errors.

7.2.6.2 Boolean

Boolean parameters represent two states. The "ON" state (logically true) is represented by "ON" or a numeric value 1. The "OFF" state (logically untrue) is represented by "OFF" or the numeric value 0.

Querying boolean parameters

When you query boolean parameters, the system returns either the value 1 ("ON") or the value 0 ("OFF").

Example:

Setting: `DISPlay:WINDow:ZOOM:STATe ON`

Query: `DISPlay:WINDow:ZOOM:STATe?` would return 1

7.2.6.3 Character Data

Character data follows the syntactic rules of keywords. You can enter text using a short or a long form. For more information see [chapter 7.2.2, "Long and Short Form"](#), on page 87.

Querying text parameters

When you query text parameters, the system returns its short form.

Example:

Setting: `SENSe:BANDwidth:RESolution:TYPE NORMal`

Query: `SENSe:BANDwidth:RESolution:TYPE?` would return `NORM`

7.2.6.4 Character Strings

Strings are alphanumeric characters. They have to be in straight quotation marks. You can use a single quotation mark (') or a double quotation mark (").

Example:

`INSTRument:DELeTe 'Spectrum'`

7.2.6.5 Block Data

Block data is a format which is suitable for the transmission of large amounts of data.

The ASCII character # introduces the data block. The next number indicates how many of the following digits describe the length of the data block. In the example the 4 following digits indicate the length to be 5168 bytes. The data bytes follow. During the transmission of these data bytes all end or other control signs are ignored until all bytes are transmitted. #0 specifies a data block of indefinite length. The use of the indefinite format requires a `NL^END` message to terminate the data block. This format is useful when the length of the transmission is not known or if speed or other considerations prevent segmentation of the data into blocks of definite length.

7.3 Remote Commands to Select the LTE Application

INSTrument:CREate:DUPLicate	91
INSTrument:CREate[:NEW]	91
INSTrument:CREate:REPLace	91
INSTrument:DELeTe	92
INSTrument:LIST?	92
INSTrument:REName	93
INSTrument[:SElect]	93

INSTrument:CREate:DUPLicate

This command duplicates the currently selected measurement channel, i.e. creates a new measurement channel of the same type and with the identical measurement settings. The name of the new channel is the same as the copied channel, extended by a consecutive number (e.g. "Spectrum" -> "Spectrum 2").

The channel to be duplicated must be selected first using the `INST:SEL` command.

This command is not available if the MSRA Master channel is selected.

Example:

```
INST:SEL 'Spectrum'
```

```
INST:CRE:DUPL
```

Duplicates the channel named 'Spectrum' and creates a new measurement channel named 'Spectrum 2'.

Usage: Event

INSTrument:CREate[:NEW] <ChannelType>, <ChannelName>

This command adds an additional measurement channel.

The number of measurement channels you can configure at the same time depends on available memory.

Parameters:

<ChannelType> Channel type of the new channel.
For a list of available channel types see [INSTrument:LIST?](#) on page 92.

<ChannelName> String containing the name of the channel. The channel name is displayed as the tab label for the measurement channel.
Note: If the specified name for a new channel already exists, the default name, extended by a sequential number, is used for the new channel (see [INSTrument:LIST?](#) on page 92).

Example:

```
INST:CRE SAN, 'Spectrum 2'
```

Adds an additional spectrum display named "Spectrum 2".

INSTrument:CREate:REPLace <ChannelName1>,<ChannelType>,<ChannelName2>

This command replaces a measurement channel with another one.

Setting parameters:

- <ChannelName1> String containing the name of the measurement channel you want to replace.
- <ChannelType> Channel type of the new channel.
For a list of available channel types see [INSTrument:LIST?](#) on page 92.
- <ChannelName2> String containing the name of the new channel.
Note: If the specified name for a new channel already exists, the default name, extended by a sequential number, is used for the new channel (see [INSTrument:LIST?](#) on page 92).

Example:

```
INST:CRE:REPL 'Spectrum2',IQ,'IQAnalyzer'
```

Replaces the channel named 'Spectrum2' by a new measurement channel of type 'IQ Analyzer' named 'IQAnalyzer'.

Usage:

Setting only

INSTrument:DELeTe <ChannelName>

This command deletes a measurement channel.

If you delete the last measurement channel, the default "Spectrum" channel is activated.

Parameters:

- <ChannelName> String containing the name of the channel you want to delete.
A measurement channel must exist in order to be able delete it.

Example:

```
INST:DEL 'Spectrum4'
```

Deletes the channel with the name 'Spectrum4'.

Usage:

Event

INSTrument:LIST?

This command queries all active measurement channels. This is useful in order to obtain the names of the existing measurement channels, which are required in order to replace or delete the channels.

Return values:

- <ChannelType>,
<ChannelName> For each channel, the command returns the channel type and channel name (see tables below).
Tip: to change the channel name, use the [INSTrument:REName](#) command.

Example:

```
INST:LIST?
```

Result for 3 measurement channels:
'ADEM', 'Analog Demod', 'IQ', 'IQ Analyzer', 'IQ', 'IQ Analyzer2'

Usage:

Query only

Table 7-1: Available measurement channel types and default channel names in Signal and Spectrum Analyzer mode

Application	<ChannelType> Parameter	Default Channel Name*)
Spectrum	SANALYZER	Spectrum
I/Q Analyzer	IQ	IQ Analyzer
Analog Demodulation (R&S FPS-K7)	ADEM	Analog Demod
GSM (R&S FPS-K10)	GSM	GSM
Noise (R&S FPS-K30)	NOISE	Noise
Phase Noise (R&S FPS-K40)	PNOISE	Phase Noise
VSA (R&S FPS-K70)	DDEM	VSA
3GPP FDD BTS (R&S FPS-K72)	BWCD	3G FDD BTS
3GPP FDD UE (R&S FPS-K73)	MWCD	3G FDD UE
TD-SCDMA BTS (R&S FPS-K76)	BTDS	TD-SCDMA BTS
TD-SCDMA UE (R&S FPS-K77)	MTDS	TD-SCDMA UE
cdma2000 BTS (R&S FPS-K82)	BC2K	CDMA2000 BTS
cdma2000 MS (R&S FPS-K83)	MC2K	CDMA2000 MS
1xEV-DO BTS (R&S FPS-K84)	BDO	1xEV-DO BTS
1xEV-DO MS (R&S FPS-K85)	MDO	1xEV-DO MS
WLAN (R&S FPS-K91)	WLAN	WLAN
LTE (R&S FPS-K10x)	LTE	LTE

Note: the default channel name is also listed in the table. If the specified name for a new channel already exists, the default name, extended by a sequential number, is used for the new channel.

INSTrument:REName <ChannelName1>, <ChannelName2>

This command renames a measurement channel.

Parameters:

<ChannelName1> String containing the name of the channel you want to rename.

<ChannelName2> String containing the new channel name.
Note that you can not assign an existing channel name to a new channel; this will cause an error.

Example:

```
INST:REN 'Spectrum2', 'Spectrum3'
```

Renames the channel with the name 'Spectrum2' to 'Spectrum3'.

Usage:

Setting only

INSTrument[:SElect] <ChannelType>

This command selects a new measurement channel with the defined channel type.

Parameters:
 <ChannelType> **LTE**
 LTE measurement channel (R&S FPS-K10x)

Example: INST LTE
 Selects the LTE application.

7.4 General Window Commands

The following commands are required to configure general window layout, independent of the application.

DISPlay:FORMat	94
DISPlay[:WINDow<n>]:SIZE	94

DISPlay:FORMat <Format>

This command determines which tab is displayed.

Parameters:
 <Format> **SPLit**
 Displays the MultiView tab with an overview of all active channels

SINGLE
 Displays the measurement channel that was previously focused.

*RST: SING

Example: DISP:FORM SPL

DISPlay[:WINDow<n>]:SIZE <Size>

This command maximizes the size of the selected result display window *temporarily*. To change the size of several windows on the screen permanently, use the LAY:SP command (see LAYout:SPlitter on page 98).

Parameters:
 <Size> **LARGE**
 Maximizes the selected window to full screen.
 Other windows are still active in the background.

SMALI
 Reduces the size of the selected window to its original size.
 If more than one measurement window was displayed originally, these are visible again.

*RST: SMALI

Example: DISP:WIND2:LARG

7.5 Working with Windows in the Display

The following commands are required to change the evaluation type and rearrange the screen layout for a measurement channel as you do using the SmartGrid in manual operation. Since the available evaluation types depend on the selected application, some parameters for the following commands also depend on the selected measurement channel.

LAYout:ADD[:WINDow]?	95
LAYout:CATalog[:WINDow]?	97
LAYout:IDENtify[:WINDow]?	97
LAYout:REMove[:WINDow]	97
LAYout:REPLace[:WINDow]	98
LAYout:SPLitter	98
LAYout:WINDow<n>:ADD?	100
LAYout:WINDow<n>:IDENtify?	100
LAYout:WINDow<n>:REMove	100
LAYout:WINDow<n>:REPLace	101

LAYout:ADD[:WINDow]? <WindowName>,<Direction>,<WindowType>

This command adds a window to the display in the active measurement channel.

This command is always used as a query so that you immediately obtain the name of the new window as a result.

To replace an existing window, use the `LAYout:REPLace[:WINDow]` command.

Parameters:

<code><WindowName></code>	String containing the name of the existing window the new window is inserted next to. By default, the name of a window is the same as its index. To determine the name and index of all active windows, use the <code>LAYout:CATalog[:WINDow]?</code> query.
<code><Direction></code>	LEFT RIGHT ABOVE BELOW Direction the new window is added relative to the existing window.
<code><WindowType></code>	text value Type of result display (evaluation method) you want to add. See the table below for available parameter values.

Return values:

<code><NewWindowName></code>	When adding a new window, the command returns its name (by default the same as its number) as a result.
------------------------------------	---

Example:

```
LAY:ADD? '1', LEFT, MTAB
```

Result:

```
'2'
```

Adds a new window named '2' with a marker table to the left of window 1.

Usage:	Query only
Manual operation:	See "Capture Buffer" on page 14
	See "EVM vs Carrier" on page 14
	See "EVM vs Symbol" on page 15
	See "EVM vs Subframe" on page 16
	See "Power Spectrum" on page 16
	See "Inband Emission" on page 17
	See "Spectrum Flatness" on page 17
	See "Spectrum Flatness SRS" on page 18
	See "Channel Group Delay" on page 18
	See "Spectrum Flatness Difference" on page 19
	See "Constellation Diagram" on page 19
	See "CCDF" on page 20
	See "Allocation Summary" on page 20
	See "Bit Stream" on page 21
	See "EVM vs Sym x Carr" on page 21
	See "Power vs Symbol x Carrier" on page 22
	See "Result Summary" on page 22
	See "Marker Table" on page 25

Table 7-2: <WindowType> parameter values for LTE Uplink Measurement application

Parameter value	Window type
ASUM	Allocation Summary
BSTR	Bitstream
CBUF	Capture Buffer
CCDF	CCDF
CONS	Constellation Diagram
EVCA	EVM vs Carrier
EVSU	EVM vs Subframe
EVSY	EVM vs Symbol
EVSC	EVM vs Symbol X Carrier
FEVS	Frequency Error vs Symbol
GDEL	Group Delay
IE	Inband Emission
IEA	Inband Emission All
MTAB	Marker Table
PSPE	Power Spectrum
PVSC	Power vs Symbol X Carrier
RSUM	Result Summary
SFD	Spectrum Flatness Difference

Parameter value	Window type
SFL	Spectrum Flatness
SFSR	Spectrum Flatness SRS

LAYout:CATalog[:WINDow]?

This command queries the name and index of all active windows in the active measurement channel from top left to bottom right. The result is a comma-separated list of values for each window, with the syntax:

<WindowName_1>,<WindowIndex_1>..<WindowName_n>,<WindowIndex_n>

Return values:

<WindowName> string
Name of the window.
In the default state, the name of the window is its index.

<WindowIndex> **numeric value**
Index of the window.

Example:

LAY:CAT?

Result:

'2',2,'1',1

Two windows are displayed, named '2' (at the top or left), and '1' (at the bottom or right).

Usage: Query only

LAYout:IDENTify[:WINDow]? <WindowName>

This command queries the **index** of a particular display window in the active measurement channel.

Note: to query the **name** of a particular window, use the [LAYout:WINDow<n>:IDENTify?](#) query.

Query parameters:

<WindowName> String containing the name of a window.

Return values:

<WindowIndex> Index number of the window.

Usage: Query only

LAYout:REMOve[:WINDow] <WindowName>

This command removes a window from the display in the active measurement channel.

Parameters:

<WindowName> String containing the name of the window.
In the default state, the name of the window is its index.

Usage: Event

LAYout:REPLace[:WINDow] <WindowName>,<WindowType>

This command replaces the window type (for example from "Diagram" to "Result Summary") of an already existing window in the active measurement channel while keeping its position, index and window name.

To add a new window, use the [LAYout:ADD\[:WINDow\]?](#) command.

Parameters:

<WindowName> String containing the name of the existing window. By default, the name of a window is the same as its index. To determine the name and index of all active windows in the active measurement channel, use the [LAYout:CATalog\[:WINDow\]?](#) query.

<WindowType> Type of result display you want to use in the existing window. See [LAYout:ADD\[:WINDow\]?](#) on page 95 for a list of available window types.

Example: `LAY:REPL:WIND '1',MTAB`
Replaces the result display in window 1 with a marker table.

LAYout:SPLitter <Index1>,<Index2>,<Position>

This command changes the position of a splitter and thus controls the size of the windows on each side of the splitter.

Compared to the [DISPlay\[:WINDow<n>\]:SIZE](#) on page 94 command, the `LAYout:SPLitter` changes the size of all windows to either side of the splitter permanently, it does not just maximize a single window temporarily.

Note that windows must have a certain minimum size. If the position you define conflicts with the minimum size of any of the affected windows, the command will not work, but does not return an error.

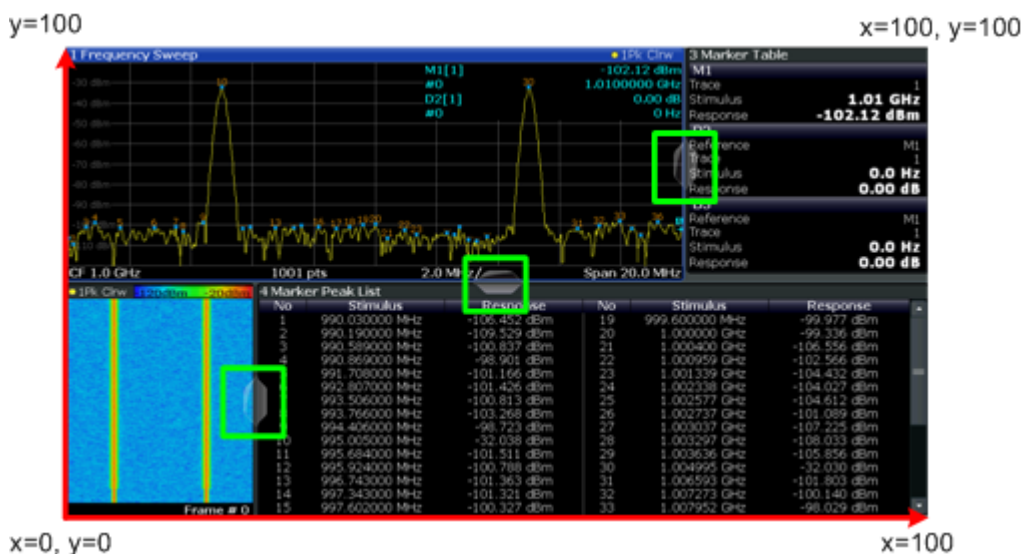

Fig. 7-1: SmartGrid coordinates for remote control of the splitters

Parameters:

- <Index1> The index of one window the splitter controls.
- <Index2> The index of a window on the other side of the splitter.
- <Position> New vertical or horizontal position of the splitter as a fraction of the screen area (without channel and status bar and softkey menu).
The point of origin (x = 0, y = 0) is in the lower left corner of the screen. The end point (x = 100, y = 100) is in the upper right corner of the screen. (See figure 7-1.)
The direction in which the splitter is moved depends on the screen layout. If the windows are positioned horizontally, the splitter also moves horizontally. If the windows are positioned vertically, the splitter also moves vertically.

Range: 0 to 100

Example: LAY:SPL 1, 3, 50
Moves the splitter between window 1 ('Frequency Sweep') and 3 ('Marker Table') to the center (50%) of the screen, i.e. in the figure above, to the left.

Example: LAY:SPL 1, 4, 70
Moves the splitter between window 1 ('Frequency Sweep') and 3 ('Marker Peak List') towards the top (70%) of the screen. The following commands have the exact same effect, as any combination of windows above and below the splitter moves the splitter vertically.

- LAY:SPL 3, 2, 70
- LAY:SPL 4, 1, 70
- LAY:SPL 2, 1, 70

LAYout:WINDow<n>:ADD? <Direction>,<WindowType>

This command adds a measurement window to the display. Note that with this command, the suffix <n> determines the existing window next to which the new window is added, as opposed to [LAYout:ADD\[:WINDow\]?](#), for which the existing window is defined by a parameter.

To replace an existing window, use the [LAYout:WINDow<n>:REPLace](#) command.

This command is always used as a query so that you immediately obtain the name of the new window as a result.

Parameters:

<Direction> LEFT | RIGHT | ABOVE | BELOW
 <WindowType> Type of measurement window you want to add.
 See [LAYout:ADD\[:WINDow\]?](#) on page 95 for a list of available window types.

Return values:

<NewWindowName> When adding a new window, the command returns its name (by default the same as its number) as a result.

Example:

```
LAY:WIND1:ADD? LEFT,MTAB
```

Result:

```
'2'
```

Adds a new window named '2' with a marker table to the left of window 1.

Usage: Query only

LAYout:WINDow<n>:IDENTify?

This command queries the **name** of a particular display window (indicated by the <n> suffix) in the active measurement channel.

Note: to query the **index** of a particular window, use the [LAYout:IDENTify\[:WINDow\]?](#) command.

Return values:

<WindowName> String containing the name of a window.
 In the default state, the name of the window is its index.

Usage: Query only

LAYout:WINDow<n>:REMOve

This command removes the window specified by the suffix <n> from the display in the active measurement channel.

The result of this command is identical to the [LAYout:REMOve\[:WINDow\]](#) command.

Usage: Event

LAYout:WINDow<n>:REPLace <WindowType>

This command changes the window type of an existing window (specified by the suffix <n>) in the active measurement channel.

The result of this command is identical to the `LAYout:REPLace[:WINDow]` command.

To add a new window, use the `LAYout:WINDow<n>:ADD?` command.

Parameters:

<WindowType> Type of measurement window you want to replace another one with.
See `LAYout:ADD[:WINDow]?` on page 95 for a list of available window types.

7.6 Performing Measurements

7.6.1 Measurements

<code>ABORt</code>	101
<code>INITiate<n>:CONTinuous</code>	102
<code>INITiate<n>[:IMMEDIATE]</code>	103
<code>[SENSe]:LTE:OOPower:ATIMing</code>	103
<code>[SENSe]:SYNC[:STATe]?</code>	103

ABORt

This command aborts the measurement in the current measurement channel and resets the trigger system.

To prevent overlapping execution of the subsequent command before the measurement has been aborted successfully, use the `*OPC?` or `*WAI` command after `ABOR` and before the next command.

For details see the "Remote Basics" chapter in the R&S FPS User Manual.

To abort a sequence of measurements by the Sequencer, use the `INITiate<n>:SEQuencer:ABORt` command.

Note on blocked remote control programs:

If a sequential command cannot be completed, for example because a triggered sweep never receives a trigger, the remote control program will never finish and the remote channel to the R&S FPS is blocked for further commands. In this case, you must interrupt processing on the remote channel first in order to abort the measurement.

To do so, send a "Device Clear" command from the control instrument to the R&S FPS on a parallel channel to clear all currently active remote channels. Depending on the used interface and protocol, send the following commands:

- **Visa:** `viClear()`

Now you can send the `ABORT` command on the remote channel performing the measurement.

Example: `ABOR; :INIT:IMM`
Aborts the current measurement and immediately starts a new one.

Example: `ABOR; *WAI`
`INIT:IMM`
Aborts the current measurement and starts a new one once abortion has been completed.

Usage: Event
SCPI confirmed

`INITiate<n>:CONTinuous <State>`

This command controls the sweep mode for an individual measurement channel.

Note that in single sweep mode, you can synchronize to the end of the measurement with `*OPC`, `*OPC?` or `*WAI`. In continuous sweep mode, synchronization to the end of the measurement is not possible. Thus, it is not recommended that you use continuous sweep mode in remote control, as results like trace data or markers are only valid after a single sweep end synchronization.

For details on synchronization see the "Remote Basics" chapter in the R&S FPS User Manual.

If the sweep mode is changed for a measurement channel while the Sequencer is active (see `INITiate<n>:SEQuencer:IMMediate` on page 104) the mode is only considered the next time the measurement in that channel is activated by the Sequencer.

Suffix:
<n> irrelevant

Parameters:
<State> `ON | OFF | 0 | 1`
ON | 1
Continuous sweep
OFF | 0
Single sweep
`*RST: 0`

Example: `INIT:CONT OFF`
Switches the sweep mode to single sweep .
`INIT:CONT ON`
Switches the sweep mode to continuous sweep .

INITiate<n>[:IMMediate]

This command starts a (single) new measurement.

You can synchronize to the end of the measurement with *OPC, *OPC? or *WAI.

For details on synchronization see the "Remote Basics" chapter in the R&S FPS User Manual.

Suffix:

<n> irrelevant

Usage: Event

[SENSe][:LTE]:OOPower:ATIMing

This command adjusts the timing for On/Off Power measurements.

Example: `OOP:ATIM`
Adjusts the On/Off Power timing.

Usage: Event

[SENSe]:SYNC[:STATe]?

This command queries the current synchronization state.

Return values:

<State> The string contains the following information.
A zero represents a failure and a one represents a successful synchronization.

Example: `SYNC:STAT?`
Would return, e.g. '1' for successful synchronization.

Usage: Query only

7.6.2 Measurement Sequences

INITiate<n>:SEQuencer:ABORt	103
INITiate<n>:SEQuencer:IMMediate	104
INITiate<n>:SEQuencer:MODE	104
SYSTem:SEQuencer	105

INITiate<n>:SEQuencer:ABORt

This command stops the currently active sequence of measurements. The Sequencer itself is not deactivated, so you can start a new sequence immediately using [INITiate<n>:SEQuencer:IMMediate](#) on page 104.

To deactivate the Sequencer use [SYSTem:SEQuencer](#) on page 105.

Suffix:
<n> irrelevant

Usage: Event

INITiate<n>:SEQuencer:IMMEDIATE

This command starts a new sequence of measurements by the Sequencer.

Its effect is similar to the `INITiate<n>[:IMMEDIATE]` command used for a single measurement.

Before this command can be executed, the Sequencer must be activated (see [SYSTem:SEQuencer](#) on page 105).

Suffix:
<n> irrelevant

Example:

```
SYST:SEQ ON
Activates the Sequencer.
INIT:SEQ:MODE SING
Sets single sequence mode so each active measurement will be
performed once.
INIT:SEQ:IMM
Starts the sequential measurements.
```

Usage: Event

INITiate<n>:SEQuencer:MODE <Mode>

This command selects the way the R&S FPS application performs measurements sequentially.

Before this command can be executed, the Sequencer must be activated (see [SYSTem:SEQuencer](#) on page 105).

A detailed programming example is provided in the "Operating Modes" chapter in the R&S FPS User Manual.

Note: In order to synchronize to the end of a sequential measurement using `*OPC`, `*OPC?` or `*WAI` you must use `SINGLE` Sequence mode.

For details on synchronization see the "Remote Basics" chapter in the R&S FPS User Manual.

Suffix:
<n> irrelevant

Parameters:

<Mode>

SINGle

Each measurement is performed once (regardless of the channel's sweep mode), considering each channels' sweep count, until all measurements in all active channels have been performed.

CONTInuous

The measurements in each active channel are performed one after the other, repeatedly (regardless of the channel's sweep mode), in the same order, until the Sequencer is stopped.

CDEFined

First, a single sequence is performed. Then, only those channels in continuous sweep mode (`INIT:CONT ON`) are repeated.

*RST: CONTInuous

Example:

```
SYST:SEQ ON
```

Activates the Sequencer.

```
INIT:SEQ:MODE SING
```

Sets single sequence mode so each active measurement will be performed once.

```
INIT:SEQ:IMM
```

Starts the sequential measurements.

SYSTem:SEQuencer <State>

This command turns the Sequencer on and off. The Sequencer must be active before any other Sequencer commands (`INIT:SEQ...`) are executed, otherwise an error will occur.

A detailed programming example is provided in the "Operating Modes" chapter in the R&S FPS User Manual.

Parameters:

<State>

ON | OFF | 0 | 1

ON | 1

The Sequencer is activated and a sequential measurement is started immediately.

OFF | 0

The Sequencer is deactivated. Any running sequential measurements are stopped. Further Sequencer commands (`INIT:SEQ...`) are not available.

*RST: 0

Example:

```

SYST:SEQ ON
Activates the Sequencer.
INIT:SEQ:MODE SING
Sets single Sequencer mode so each active measurement will
be performed once.
INIT:SEQ:IMM
Starts the sequential measurements.
SYST:SEQ OFF

```

7.7 Remote Commands to Read Trace Data

- [Using the TRACe\[:DATA\] Command](#)..... 106
- [Remote Commands to Read Measurement Results](#)..... 116

7.7.1 Using the TRACe[:DATA] Command

This chapter contains information on the TRACe:DATA command and a detailed description of the characteristics of that command.

The TRACe:DATA command queries the trace data or results of the currently active measurement or result display. The type, number and structure of the return values are specific for each result display. In case of results that have any kind of unit, the command returns the results in the unit you have currently set for that result display.

Note also that return values for results that are available for both downlink and uplink may be different.

For several result displays, the command also supports various SCPI parameters in combination with the query. If available, each SCPI parameter returns a different aspect of the results. If SCPI parameters are supported, you have to quote one in the query.

Example:

```
TRAC2:DATA? TRACE1
```

The format of the return values is either in ASCII or binary characters and depends on the format you have set with [FORMat \[:DATA\]](#).

Following this detailed description, you will find a short summary of the most important functions of the command ([TRACe<n> \[:DATA\] ?](#)).



Selecting a measurement window

Compared to the LTE application on the R&S FSQ or R&S FSV, you have to select the measurement window directly with the suffix `<n>` at `TRACe`. The range of `<n>` depends on the number of active measurement windows.

On an R&S FSQ or R&S FSV, the suffix `<n>` was not supported. On these instruments, you had to select the measurement window with `DISPlay:WINDow<n>:SElect` first.

• Adjacent Channel Leakage Ratio.....	107
• Allocation Summary.....	107
• Bit Stream.....	108
• Capture Buffer.....	109
• CCDF.....	109
• Channel and Spectrum Flatness.....	109
• Channel and Spectrum Flatness Difference.....	110
• Channel Flatness SRS.....	110
• Channel Group Delay.....	111
• Constellation Diagram.....	111
• EVM vs Carrier.....	112
• EVM vs Subframe.....	112
• EVM vs Symbol.....	112
• EVM vs Symbol x Carrier.....	112
• Frequency Error vs Symbol.....	113
• Inband Emission.....	113
• Power Spectrum.....	113
• Power vs Symbol x Carrier.....	114
• Spectrum Emission Mask.....	114
• Return Value Codes.....	114

7.7.1.1 Adjacent Channel Leakage Ratio

For the ACLR result display, the number and type of returns values depend on the parameter.

- TRACE1
Returns one value for each trace point.

7.7.1.2 Allocation Summary

For the Allocation Summary, the command returns seven values for each line of the table.

```
<subframe>, <allocation ID>, <number of RB>, <offset RB>,  
<modulation>, <absolute power>, <EVM>, ...
```

The unit for `<absolute power>` is always dBm. The unit for `<EVM>` depends on `UNIT:EVM`. All other values have no unit.

The `<allocation ID>` and `<modulation>` are encoded. For the code assignment see [chapter 7.7.1.20, "Return Value Codes"](#), on page 114.

Note that the data format of the return values is always ASCII.

Example:

Allocation Summary							
Sub-frame	Alloc. ID	Number of RB	Offset RB	Modulation	Power/dBm	EVM/%	
0	PUSCH	10	2	QPSK	-84,743	0,002	
	DMRS PUSCH			CAZAC	-84,743	0,002	
	SRS			CAZAC	-80,940	0,003	

TRAC:DATA? TRACE1 would return:

```
0, -40, 10, 2, 2, -84.7431947342849, 2.68723483754626E-06,
0, -41, 0, 0, 6, -84.7431432845264, 2.37549449584568E-06,
0, -42, 0, 0, 6, -80.9404231343884, 3.97834623871343E-06,
...
```

7.7.1.3 Bit Stream

For the Bit Stream result display, the command returns five values and the bitstream for each line of the table.

```
<subframe>, <modulation>, <# of symbols/bits>,
<hexadecimal/binary numbers>,...
```

All values have no unit. The format of the bitstream depends on [Bit Stream Format](#).

The <modulation> is encoded. For the code assignment see [chapter 7.7.1.20, "Return Value Codes"](#), on page 114.

For symbols or bits that are not transmitted, the command returns

- "FFF" if the bit stream format is "Symbols"
- "9" if the bit stream format is "Bits".

For symbols or bits that could not be decoded because the number of layer exceeds the number of receive antennas, the command returns

- "FFE" if the bit stream format is "Symbols"
- "8" if the bit stream format is "Bits".

Note that the data format of the return values is always ASCII.

Example:

Sub-frame	Allocation ID	Code-word	Modulation	Symbol Index	Bit Stream
0	PUSCH	1/1	QPSK	0	03 01 02 03 03 00 00 00 01 02 02 01 02 01 00 00
0	PUSCH	1/1	QPSK	16	00 03 03 03 02 02 01 00 03 01 02 03 03 03 03 01
0	PUSCH	1/1	QPSK	32	03 03 00 00 03 01 02 00 01 00 02 00 02 00 00 03

TRAC:DATA? TRACE1 would return:

```
0, -40, 0, 2, 0, 03, 01, 02, 03, 03, 00, 00, 00, 01, 02, 02, ...
<continues like this until the next data block starts or the end of data is
reached>
0, -40, 0, 2, 32, 03, 03, 00, 00, 03, 01, 02, 00, 01, 00, ...
```

7.7.1.4 Capture Buffer

For the Capture Buffer result display, the command returns one value for each I/Q sample in the capture buffer.

<absolute power>, ...

The unit is always dBm.

The following parameters are supported.

- TRACE1

7.7.1.5 CCDF

For the CCDF result display, the type of return values depends on the parameter.

- TRACE1
Returns the probability values (y-axis).
<# of values>, <probability>, ...
The unit is always %.
The first value that is returned is the number of the following values.
- TRACE2
Returns the corresponding power levels (x-axis).
<# of values>, <relative power>, ...
The unit is always dB.
The first value that is returned is the number of the following values.

7.7.1.6 Channel and Spectrum Flatness

For the Channel Flatness result display, the command returns one value for each trace point.

<relative power>, ...

The unit is always dB.

The following parameters are supported.

- TRACE1

Returns the average power over all subframes.

- TRACE2
Returns the minimum power found over all subframes. If you are analyzing a particular subframe, it returns nothing.
- TRACE3
Returns the maximum power found over all subframes. If you are analyzing a particular subframe, it returns nothing.

7.7.1.7 Channel and Spectrum Flatness Difference

For the Channel Flatness Difference result display, the command returns one value for each trace point.

```
<relative power>, ...
```

The unit is always dB. The number of values depends on the selected LTE bandwidth.

The following parameters are supported.

- TRACE1
Returns the average power over all subframes.
- TRACE2
Returns the minimum power found over all subframes. If you are analyzing a particular subframe, it returns nothing.
- TRACE3
Returns the maximum power found over all subframes. If you are analyzing a particular subframe, it returns nothing.

7.7.1.8 Channel Flatness SRS

For the Channel Flatness SRS result display, the command returns one value for each trace point.

```
<relative power>, ...
```

The unit is always dB.

The following parameters are supported.

- TRACE1
Returns the average power over all subframes.
- TRACE2
Returns the minimum power found over all subframes. If you are analyzing a particular subframe, it returns nothing.
- TRACE3
Returns the maximum power found over all subframes. If you are analyzing a particular subframe, it returns nothing.

7.7.1.9 Channel Group Delay

For the Channel Group Delay result display, the command returns one value for each trace point.

<group delay>, ...

The unit is always ns. The number of values depends on the selected LTE bandwidth.

The following parameters are supported.

- TRACE1
Returns the average group delay over all subframes.
- TRACE2
Returns the minimum group delay found over all subframes. If you are analyzing a particular subframe, it returns nothing.
- TRACE3
Returns the maximum group delay found over all subframes. If you are analyzing a particular subframe, it returns nothing.

7.7.1.10 Constellation Diagram

For the Constellation Diagram, the command returns two values for each constellation point.

```
<I[SF0][Sym0][Carrier1]>, <Q[SF0][Sym0][Carrier1]>, ..., <I[SF0][Sym0][Carrier(n)]>, <Q[SF0][Sym0][Carrier(n)]>,
<I[SF0][Sym1][Carrier1]>, <Q[SF0][Sym1][Carrier1]>, ..., <I[SF0][Sym1][Carrier(n)]>, <Q[SF0][Sym1][Carrier(n)]>,
<I[SF0][Sym(n)][Carrier1]>, <Q[SF0][Sym(n)][Carrier1]>, ..., <I[SF0][Sym(n)][Carrier(n)]>, <Q[SF0][Sym(n)][Carrier(n)]>,
<I[SF1][Sym0][Carrier1]>, <Q[SF1][Sym0][Carrier1]>, ..., <I[SF1][Sym0][Carrier(n)]>, <Q[SF1][Sym0][Carrier(n)]>,
<I[SF1][Sym1][Carrier1]>, <Q[SF1][Sym1][Carrier1]>, ..., <I[SF1][Sym1][Carrier(n)]>, <Q[SF1][Sym1][Carrier(n)]>,
<I[SF(n)][Sym(n)][Carrier1]>, <Q[SF(n)][Sym(n)][Carrier1]>, ..., <I[SF(n)][Sym(n)][Carrier(n)]>, <Q[SF(n)][Sym(n)][Carrier(n)]>
```

With SF = subframe and Sym = symbol of that subframe.

The I and Q values have no unit.

The number of return values depends on the constellation selection. By default, it returns all resource elements including the DC carrier.

The following parameters are supported.

- TRACE1
Returns all constellation points included in the selection.
- TRACE2
Returns the constellation points of the reference symbols included in the selection.
- TRACE3
Returns the constellation points of the SRS included in the selection.

7.7.1.11 EVM vs Carrier

For the EVM vs Carrier result display, the command returns one value for each subcarrier that has been analyzed.

<EVM>, ...

The unit depends on [UNIT:EVM](#).

The following parameters are supported.

- TRACE1
Returns the average EVM over all subframes
- TRACE2
Returns the minimum EVM found over all subframes. If you are analyzing a particular subframe, it returns nothing.
- TRACE3
Returns the maximum EVM found over all subframes. If you are analyzing a particular subframe, it returns nothing.

7.7.1.12 EVM vs Subframe

For the EVM vs Subframe result display, the command returns one value for each subframe that has been analyzed.

<EVM>, ...

The unit depends on [UNIT:EVM](#).

The following parameters are supported.

- TRACE1

7.7.1.13 EVM vs Symbol

For the EVM vs Symbol result display, the command returns one value for each OFDM symbol that has been analyzed.

<EVM>, ...

For measurements on a single subframe, the command returns the symbols of that subframe only.

The unit depends on [UNIT:EVM](#).

The following parameters are supported.

- TRACE1

7.7.1.14 EVM vs Symbol x Carrier

For the EVM vs Symbol x Carrier, the command returns one value for each resource element.

<EVM[Symbol(0),Carrier(1)]>, ..., <EVM[Symbol(0),Carrier(n)]>,

```
<EVM[Symbol(1),Carrier(1)]>, ..., <EVM[Symbol(1),Carrier(n)]>,
...
```

```
<EVM[Symbol(n),Carrier(1)]>, ..., <EVM[Symbol(n),Carrier(n)]>,
```

The unit depends on `UNIT:EVM`.

Resource elements that are unused return `NAN`.

The following parameters are supported.

- TRACE1

7.7.1.15 Frequency Error vs Symbol

For the Frequency Error vs Symbol result display, the command returns one value for each OFDM symbol that has been analyzed.

```
<frequency error>, ...
```

The unit is always Hz.

The following parameters are supported.

- TRACE1

7.7.1.16 Inband Emission

For the Inband Emission result display, the number and type of returns values depend on the parameter.

- TRACE1
Returns the relative resource block indices (x-axis values).
`<RB index>, ...`
The resource block index has no unit.
- TRACE2
Returns one value for each resource block index.
`<relative power>, ...`
The unit of the relative inband emission is dB.
- TRACE3
Returns the data points of the upper limit line.
`<limit>, ...`
The unit is always dB.

Note that you have to select a particular subframe to get results.

7.7.1.17 Power Spectrum

For the Power Spectrum result display, the command returns one value for each trace point.

```
<power>, ...
```

The unit is always dBm/Hz.

The following parameters are supported.

- TRACE1

7.7.1.18 Power vs Symbol x Carrier

For the Power vs Symbol x Carrier, the command returns one value for each resource element.

```
<P[Symbol(0),Carrier(1)]>, ..., <P[Symbol(0),Carrier(n)]>,
<P[Symbol(1),Carrier(1)]>, ..., <P[Symbol(1),Carrier(n)]>,
...
<P[Symbol(n),Carrier(1)]>, ..., <P[Symbol(n),Carrier(n)]>
```

with P = Power of a resource element.

The unit is always dBm.

Resource elements that are unused return NAN.

The following parameters are supported.

- TRACE1

7.7.1.19 Spectrum Emission Mask

For the SEM measurement, the number and type of returns values depend on the parameter.

- TRACE1
Returns one value for each trace point.
<absolute power>, ...
The unit is always dBm.
- LIST
Returns the contents of the SEM table. For every frequency in the spectrum emission mask, it returns 11 values.
<index>, <start frequency in Hz>, <stop frequency in Hz>, <RBW in Hz>, <limit fail frequency in Hz>, <absolute power in dBm>, <relative power in dBc>, <limit distance in dB>, <limit check result>, <reserved>, <reserved>...
The <limit check result> is either a 0 (for PASS) or a 1 (for FAIL).

7.7.1.20 Return Value Codes

This chapter contains a list for encoded return values.

<allocation ID>

Represents the allocation ID. The value is a number in the range {1...70}.

- 1 = Reference symbol
- 0 = Data symbol

- -1 = Invalid
- -40 = PUSCH
- -41 = DMRS PUSCH
- -42 = SRS PUSCH
- -50 = PUCCH
- -51 = DMRS PUCCH
- -70 = PRACH

<channel type>

- 0 = TX channel
- 1 = adjacent channel
- 2 = alternate channel

<codeword>

Represents the codeword of an allocation. The range is {0...6}.

- 0 = 1/1
- 1 = 1/2
- 2 = 2/2
- 3 = 1/4
- 4 = 2/4
- 5 = 3/4
- 6 = 4/4

<modulation>

Represents the modulation scheme. The range is {0...14}.

- 0 = unrecognized
- 1 = RBPSK
- 2 = QPSK
- 3 = 16QAM
- 4 = 64QAM
- 5 = 8PSK
- 6 = PSK
- 7 = mixed modulation
- 8 = BPSK

<number of symbols or bits>

In hexadecimal mode, this represents the number of symbols to be transmitted. In binary mode, it represents the number of bits to be transmitted.

TRACe<n>[:DATA]? <Result>

This command returns the trace data for the current measurement or result display.

For more information see [chapter 7.7.1, "Using the TRACe\[:DATA\] Command"](#), on page 106.

Query parameters:

<TraceNumber> **TRACE1 | TRACE2 | TRACE3**

LIST

Example:

TRAC2? TRACE1

Queries results of the second measurement window. The type of data that is returned by the parameter (TRACE1) depends on the result display shown in measurement window 2.

Usage:

Query only

7.7.2 Remote Commands to Read Measurement Results

CALCulate<n>:MARKer<m>:FUNctIon:POWer:RESult[:CURRent]?.....	116
FORMat[:DATA].....	117

CALCulate<n>:MARKer<m>:FUNctIon:POWer:RESult[:CURRent]? <ResultType>

This command queries the current results of the ACLR measurement or the total signal power level of the SEM measurement.

To get a valid result, you have to perform a complete measurement with synchronization to the end of the measurement before reading out the result. This is only possible for single sweeps.

Suffix:

<m> 1

Query parameters:

<ResultType>

CPOW

This parameter queries the channel power of the reference range.

MCAC

Queries the channel powers of the ACLR, MC ACLR and Cumulative ACLR measurements as shown in the ACLR table.

Where available, this parameter also queries the power of the adjacent channels (for example in the ACLR measurement).

GACLR

Queries the ACLR values for each gap channel in the MC ACLR measurement.

Return values:

<Result>

Results for the Spectrum Emission Mask measurement:

Power level in dBm.

Results for the ACLR measurements:

Relative power levels of the ACLR channels. The number of return values depends on the number of transmission and adjacent channels. The order of return values is:

- <TXChannelPower> is the power of the transmission channel in dBm
- <LowerAdjChannelPower> is the relative power of the lower adjacent channel in dB
- <UpperAdjChannelPower> is the relative power of the upper adjacent channel in dB
- <1stLowerAltChannelPower> is the relative power of the first lower alternate channel in dB
- <1stUpperAltChannelPower> is the relative power of the first lower alternate channel in dB
- (...)
- <nthLowerAltChannelPower> is the relative power of a subsequent lower alternate channel in dB
- <nthUpperAltChannelPower> is the relative power of a subsequent lower alternate channel in dB

Example:

CALC1:MARK:FUNC:POW:RES? MCAC

Returns the current ACLR measurement results.

Usage:

Query only

Manual operation:

See "ACLR" on page 26
 See "Multi Carrier ACLR" on page 28

FORMat[:DATA] [<Format>]

This command specifies the data format for the data transmission between the LTE measurement application and the remote client. Supported formats are ASCII or REAL32.

Parameters:

<Format> ASCII | REAL
 *RST: ASCII

Example:

FORM REAL
 The software will send binary data in Real32 data format.

7.8 Remote Commands to Read Numeric Results

- [Frame Results](#)..... 118
- [Result for Selection](#)..... 120
- [Marker Table](#)..... 125

7.8.1 Frame Results

FETCh:SUMMary:EVM:SDQP[:AVERAge]?	118
FETCh:SUMMary:EVM:SDSF[:AVERAge]?	118
FETCh:SUMMary:EVM:SDST[:AVERAge]?	118
FETCh:SUMMary:EVM:UCCD[:AVERAge]?	119
FETCh:SUMMary:EVM:UCCH[:AVERAge]?	119
FETCh:SUMMary:EVM:UPRA[:AVERAge]?	119
FETCh:SUMMary:EVM:USQP[:AVERAge]?	120
FETCh:SUMMary:EVM:USSF[:AVERAge]?	120
FETCh:SUMMary:EVM:USST[:AVERAge]?	120

FETCh:SUMMary:EVM:SDQP[:AVERAge]?

This command queries the EVM of all DMRS resource elements with QPSK modulation of the PUSCH.

Return values:

<EVM> <numeric value>
 EVM in % or dB, depending on the unit you have set.

Example:

FETC : SUMM : EVM : SDQP ?
 Returns the EVM of all DMRS resource elements with QPSK modulation.

Usage: Query only

Manual operation: See ["Result Summary"](#) on page 22

FETCh:SUMMary:EVM:SDSF[:AVERAge]?

This command queries the EVM of all DMRS resource elements with 64QAM modulation of the PUSCH.

Return values:

<EVM> <numeric value>
 EVM in % or dB, depending on the unit you have set.

Example:

FETC : SUMM : EVM : SDSF ?
 Returns the maximum EVM of all DMRS resource elements with 64QAM modulation.

Usage: Query only

Manual operation: See ["Result Summary"](#) on page 22

FETCh:SUMMary:EVM:SDST[:AVERAge]?

This command queries the EVM of all DMRS resource elements with 16QAM modulation of the PUSCH.

Return values:

<EVM> <numeric value>
EVM in % or dB, depending on the unit you have set.

Example:

FETC : SUMM : EVM : SDST ?
Returns the EVM of all DMRS resource elements with 16QAM modulation.

Usage:

Query only

Manual operation: See "[Result Summary](#)" on page 22

FETCh:SUMMary:EVM:UCCD[:AVERAge]?

This command queries the EVM of all DMRS resource elements of the PUCCH as shown in the result summary.

Return values:

<EVM> EVM in % or dB, depending on the unit you have set.

Example:

FETC : SUMM : EVM : UCCD ?
Returns the average EVM of all DMRS resource elements.

Usage:

Query only

Manual operation: See "[Result Summary](#)" on page 22

FETCh:SUMMary:EVM:UCCH[:AVERAge]?

This command queries the EVM of all resource elements of the PUCCH as shown in the result summary.

Return values:

<EVM> EVM in % or dB, depending on the unit you have set.

Example:

FETC : SUMM : EVM : UCCH ?
Returns the average EVM of all resource elements.

Usage:

Query only

Manual operation: See "[Result Summary](#)" on page 22

FETCh:SUMMary:EVM:UPRA[:AVERAge]?

This command queries the EVM of all resource elements of the PRACH as shown in the result summary.

Return values:

<EVM> EVM in % or dB, depending on the unit you have set.

Example:

FETC : SUMM : EVM : UPRA ?
Returns the average EVM of all resource elements.

Usage:

Query only

Manual operation: See "[Result Summary](#)" on page 22

FETCh:SUMMary:EVM:USQP[:AVERAge]?

This query returns the EVM for all QPSK-modulated resource elements of the PUSCH.

Return values:

<EVM> <numeric value>
EVM in % or dB, depending on the unit you have set.

Example:

FETC : SUMM : EVM : USQP ?
Queries the PUSCH QPSK EVM.

Usage: Query only

Manual operation: See ["Result Summary"](#) on page 22

FETCh:SUMMary:EVM:USSF[:AVERAge]?

This command queries the EVM for all 64QAM-modulated resource elements of the PUSCH.

Return values:

<EVM> <numeric value>
EVM in % or dB, depending on the unit you have set.

Example:

FETC : SUMM : EVM : USSF ?
Queries the PUSCH 64QAM EVM.

Usage: Query only

Manual operation: See ["Result Summary"](#) on page 22

FETCh:SUMMary:EVM:USST[:AVERAge]?

This query returns the the EVM for all 16QAM-modulated resource elements of the PUSCH.

Return values:

<EVM> EVM in % or dB, depending on the unit you have set.

Example:

FETC : SUMM : EVM : USST ?
Queries the PUSCH 16QAM EVM.

Usage: Query only

Manual operation: See ["Result Summary"](#) on page 22

7.8.2 Result for Selection

FETCh[:CC<cci>]:SUMMary:CRESt[:AVERAge]?	121
FETCh[:CC<cci>]:SUMMary:EVM[:ALL]:MAXimum?	121
FETCh[:CC<cci>]:SUMMary:EVM[:ALL]:MINimum?	121
FETCh[:CC<cci>]:SUMMary:EVM[:ALL][:AVERAge]?	121
FETCh[:CC<cci>]:SUMMary:EVM:PCHannel:MAXimum?	122

FETCh[:CC<cci>]:SUMMary:EVM:PCHannel:MINimum?	122
FETCh[:CC<cci>]:SUMMary:EVM:PCHannel[:AVERage]?	122
FETCh[:CC<cci>]:SUMMary:EVM:PSIGnal:MAXimum?	122
FETCh[:CC<cci>]:SUMMary:EVM:PSIGnal:MINimum?	122
FETCh[:CC<cci>]:SUMMary:EVM:PSIGnal[:AVERage]?	122
FETCh[:CC<cci>]:SUMMary:FERRor:MAXimum?	123
FETCh[:CC<cci>]:SUMMary:FERRor:MINimum?	123
FETCh[:CC<cci>]:SUMMary:FERRor[:AVERage]?	123
FETCh[:CC<cci>]:SUMMary:GIMBalance:MAXimum?	123
FETCh[:CC<cci>]:SUMMary:GIMBalance:MINimum?	123
FETCh[:CC<cci>]:SUMMary:GIMBalance[:AVERage]?	123
FETCh[:CC<cci>]:SUMMary:IQOFset:MAXimum?	123
FETCh[:CC<cci>]:SUMMary:IQOFset:MINimum?	123
FETCh[:CC<cci>]:SUMMary:IQOFset[:AVERage]?	123
FETCh[:CC<cci>]:SUMMary:POWer:MAXimum?	124
FETCh[:CC<cci>]:SUMMary:POWer:MINimum?	124
FETCh[:CC<cci>]:SUMMary:POWer[:AVERage]?	124
FETCh[:CC<cci>]:SUMMary:QUADerror:MAXimum?	124
FETCh[:CC<cci>]:SUMMary:QUADerror:MINimum?	124
FETCh[:CC<cci>]:SUMMary:QUADerror[:AVERage]?	124
FETCh[:CC<cci>]:SUMMary:SERRor:MAXimum?	125
FETCh[:CC<cci>]:SUMMary:SERRor:MINimum?	125
FETCh[:CC<cci>]:SUMMary:SERRor[:AVERage]?	125
FETCh:SUMMary:TFRame?	125

FETCh[:CC<cci>]:SUMMary:CRESt[:AVERage]?

This command queries the average crest factor as shown in the result summary.

Suffix:

<cci> 1..2

Return values:

<CrestFactor> <numeric value>
Crest Factor in dB.

Example:

FETC:SUMM:CRES?
Returns the current crest factor in dB.

Usage:

Query only

Manual operation: See "[Result Summary](#)" on page 22

FETCh[:CC<cci>]:SUMMary:EVM[:ALL]:MAXimum? FETCh[:CC<cci>]:SUMMary:EVM[:ALL]:MINimum? FETCh[:CC<cci>]:SUMMary:EVM[:ALL][:AVERage]?

This command queries the EVM of all resource elements.

Suffix:

<cci> 1..2

Return values:

<EVM> <numeric value>
 Minimum, maximum or average EVM, depending on the last command syntax element.
 The unit is % or dB, depending on your selection.

Example:

FETC : SUMM : EVM?
 Returns the mean value.

Usage:

Query only

Manual operation: See ["Result Summary"](#) on page 22

FETCh[:CC<cci>]:SUMMary:EVM:PCHannel:MAXimum?
 FETCh[:CC<cci>]:SUMMary:EVM:PCHannel:MINimum?
 FETCh[:CC<cci>]:SUMMary:EVM:PCHannel[:AVERage]?

This command queries the EVM of all physical channel resource elements.

Suffix:

<cci> 1..2

Return values:

<EVM>

Usage:

Query only

Manual operation: See ["Result Summary"](#) on page 22

FETCh[:CC<cci>]:SUMMary:EVM:PSIGnal:MAXimum?
 FETCh[:CC<cci>]:SUMMary:EVM:PSIGnal:MINimum?
 FETCh[:CC<cci>]:SUMMary:EVM:PSIGnal[:AVERage]?

This command queries the EVM of all physical signal resource elements.

Suffix:

<cci> 1..2

Return values:

<EVM> <numeric value>
 Minimum, maximum or average EVM, depending on the last command syntax element.
 The unit is % or dB, depending on your selection.

Example:

FETC : SUMM : EVM : PSIG?
 Returns the mean value.

Usage:

Query only

Manual operation: See ["Result Summary"](#) on page 22

FETCh[:CC<cci>]:SUMMary:FERRor:MAXimum?
FETCh[:CC<cci>]:SUMMary:FERRor:MINimum?
FETCh[:CC<cci>]:SUMMary:FERRor[:AVERage]?

This command queries the frequency error.

Suffix:

<cci> 1..2

Return values:

<FreqError> <numeric value>

Minimum, maximum or average frequency error, depending on the last command syntax element.

Default unit: Hz

Example:

FETC : SUMM : FERR ?

Returns the average frequency error in Hz.

Usage:

Query only

Manual operation: See "[Result Summary](#)" on page 22

FETCh[:CC<cci>]:SUMMary:GIMBalance:MAXimum?
FETCh[:CC<cci>]:SUMMary:GIMBalance:MINimum?
FETCh[:CC<cci>]:SUMMary:GIMBalance[:AVERage]?

This command queries the I/Q gain imbalance.

Suffix:

<cci> 1..2

Return values:

<GainImbalance> <numeric value>

Minimum, maximum or average I/Q imbalance, depending on the last command syntax element.

Default unit: dB

Example:

FETC : SUMM : GIMB ?

Returns the current gain imbalance in dB.

Usage:

Query only

Manual operation: See "[Result Summary](#)" on page 22

FETCh[:CC<cci>]:SUMMary:IQOffset:MAXimum?
FETCh[:CC<cci>]:SUMMary:IQOffset:MINimum?
FETCh[:CC<cci>]:SUMMary:IQOffset[:AVERage]?

This command queries the I/Q offset.

Suffix:

<cci> 1..2

Return values:**<IQOffset>** <numeric value>

Minimum, maximum or average I/Q offset, depending on the last command syntax element.

Default unit: dB

Example:

FETC:SUMM:IQOF?

Returns the current IQ-offset in dB

Usage:

Query only

Manual operation: See ["Result Summary"](#) on page 22**FETCh[:CC<cci>]:SUMMary:POWer:MAXimum?****FETCh[:CC<cci>]:SUMMary:POWer:MINimum?****FETCh[:CC<cci>]:SUMMary:POWer[:AVERage]?**

This command queries the total power.

Suffix:**<cci>** 1..2**Return values:****<Power>** <numeric value>

Minimum, maximum or average power, depending on the last command syntax element.

Default unit: dBm

Example:

FETC:SUMM:POW?

Returns the total power in dBm

Usage:

Query only

Manual operation: See ["Result Summary"](#) on page 22**FETCh[:CC<cci>]:SUMMary:QUADerror:MAXimum?****FETCh[:CC<cci>]:SUMMary:QUADerror:MINimum?****FETCh[:CC<cci>]:SUMMary:QUADerror[:AVERage]?**

This command queries the quadrature error.

Suffix:**<cci>** 1..2**Return values:****<QuadError>** <numeric value>

Minimum, maximum or average quadrature error, depending on the last command syntax element.

Default unit: deg

Example:

FETC:SUMM:QUAD?

Returns the current mean quadrature error in degrees.

Usage:

Query only

Manual operation: See ["Result Summary"](#) on page 22

FETCh[:CC<cci>]:SUMMary:SERRor:MAXimum?
FETCh[:CC<cci>]:SUMMary:SERRor:MINimum?
FETCh[:CC<cci>]:SUMMary:SERRor[:AVERage]?

This command queries the sampling error.

Suffix:

<cci> 1..2

Return values:

<SamplingError> <numeric value>
 Minimum, maximum or average sampling error, depending on the last command syntax element.
 Default unit: ppm

Example:

FETC : SUMM : SERR ?
 Returns the current mean sampling error in ppm.

Usage: Query only

Manual operation: See ["Result Summary"](#) on page 22

FETCh:SUMMary:TFRame?

This command queries the (sub)frame start offset as shown in the Capture Buffer result display.

Note that you have to select a particular subframe; otherwise the command returns an error.

Return values:

<Offset> Time difference between the (sub)frame start and capture buffer start.
 Default unit: s

Example:

FETC : SUMM : TFR ?
 Returns the (sub)frame start offset.

Usage: Query only

Manual operation: See ["Capture Buffer"](#) on page 14

7.8.3 Marker Table

CALCulate<n>:DELTaMarker<m>:X	126
CALCulate<n>:DELTaMarker<m>:Y?	126
CALCulate<n>:MARKer<m>:X	126
CALCulate<n>:MARKer<m>:Y?	127

CALCulate<n>:DELTaMarker<m>:X <Position>

This command moves a delta marker to a particular coordinate on the x-axis.

If necessary, the command activates the delta marker and positions a reference marker to the peak power.

Example: `CALC:DELT:1?`
Outputs the absolute x-value of delta marker 1.

CALCulate<n>:DELTaMarker<m>:Y?

This command queries the relative position of a delta marker on the y-axis.

If necessary, the command activates the delta marker first.

To get a valid result, you have to perform a complete measurement with synchronization to the end of the measurement before reading out the result. This is only possible for single sweep mode.

See also [INITiate<n>:CONTinuous](#) on page 102.

The unit depends on the application of the command.

Return values:

<Position> Position of the delta marker in relation to the reference marker or the fixed reference.

Example: `INIT:CONT OFF`
Switches to single sweep mode.
`INIT;*WAI`
Starts a sweep and waits for its end.
`CALC:DELT2 ON`
Switches on delta marker 2.
`CALC:DELT2:Y?`
Outputs measurement value of delta marker 2.

Usage: Query only

CALCulate<n>:MARKer<m>:X <Position>

This command moves a marker to a particular coordinate on the x-axis.

If necessary, the command activates the marker.

If the marker has been used as a delta marker, the command turns it into a normal marker.

Parameters:

<Position> Numeric value that defines the marker position on the x-axis.
Range: The range depends on the current x-axis range.

Example: `CALC:MARK2:X 1.7MHz`
Positions marker 2 to frequency 1.7 MHz.

Manual operation: See "[Marker Table](#)" on page 25

CALCulate<n>:MARKer<m>:Y?

This command queries the position of a marker on the y-axis.

If necessary, the command activates the marker first.

To get a valid result, you have to perform a complete measurement with synchronization to the end of the measurement before reading out the result. This is only possible for single sweep mode.

See also [INITiate<n>:CONTinuous](#) on page 102.

Return values:

<Result> Result at the marker position.

Example:

```
INIT:CONT OFF
Switches to single measurement mode.
CALC:MARK2 ON
Switches marker 2.
INIT;*WAI
Starts a measurement and waits for the end.
CALC:MARK2:Y?
Outputs the measured value of marker 2.
```

Usage: Query only

Manual operation: See "[Marker Table](#)" on page 25

7.9 Remote Commands to Read Limit Check Results

- [Checking Limits for Graphical Result Displays](#)..... 127
- [Checking Limits for Numerical Result Display](#)..... 129

7.9.1 Checking Limits for Graphical Result Displays

[CALCulate<n>:LIMit<k>:ACPower:ACHannel:RESult?](#).....127

[CALCulate<n>:LIMit<k>:ACPower:ALternate:RESult?](#)..... 128

[CALCulate<n>:LIMit<k>:FAIL?](#)..... 128

CALCulate<n>:LIMit<k>:ACPower:ACHannel:RESult? <Result>

This command queries the limit check results for the adjacent channels during ACLR measurements.

Return values:

<LimitCheck> Returns two values, one for the upper and one for the lower adjacent channel.

PASSED

Limit check has passed.

FAILED

Limit check has failed.

Example:

```
CALC:LIM:ACP:ACH:RES? ALL
```

Queries the results of the adjacent channel limit check.

Usage:

Query only

Manual operation: See "[Multi Carrier ACLR](#)" on page 28

CALCulate<n>:LIMit<k>:ACPpower:ALternate:RESult? <Result>

This command queries the limit check results for the alternate channels during ACLR measurements.

Return values:

<LimitCheck> Returns two values, one for the upper and one for the lower alternate channel.

PASSED

Limit check has passed.

FAILED

Limit check has failed.

Example:

```
CALC:LIM:ACP:ALT:RES? ALL
```

Queries the results of the alternate channel limit check.

Usage:

Query only

Manual operation: See "[Multi Carrier ACLR](#)" on page 28

CALCulate<n>:LIMit<k>:FAIL?

This command queries the limit check results for all measurements that feature a limit check.

Return values:

<LimitCheck> Returns two values, one for the upper and one for the lower adjacent or alternate channel.

0

Limit check has passed.

1

Limit check has failed.

Example:

```
CALC:LIM:FAIL?
```

Queries the limit check of the active result display.

Usage:

Query only

7.9.2 Checking Limits for Numerical Result Display

CALCulate<n>:LIMit<k>:SUMMary:EVM[:ALL]:MAXimum:RESult.....	129
CALCulate<n>:LIMit<k>:SUMMary:EVM[:ALL][:AVERage]:RESult?.....	129
CALCulate<n>:LIMit<k>:SUMMary:EVM:PCHannel:MAXimum:RESult.....	130
CALCulate<n>:LIMit<k>:SUMMary:EVM:PCHannel[:AVERage]:RESult?.....	130
CALCulate<n>:LIMit<k>:SUMMary:EVM:PSIGnal:MAXimum:RESult.....	130
CALCulate<n>:LIMit<k>:SUMMary:EVM:PSIGnal[:AVERage]:RESult?.....	130
CALCulate<n>:LIMit<k>:SUMMary:EVM:SDQP[:AVERage]:RESult?.....	130
CALCulate<n>:LIMit<k>:SUMMary:EVM:SDSF[:AVERage]:RESult?.....	131
CALCulate<n>:LIMit<k>:SUMMary:EVM:SDST[:AVERage]:RESult?.....	131
CALCulate<n>:LIMit<k>:SUMMary:EVM:UCCD[:AVERage]:RESult?.....	132
CALCulate<n>:LIMit<k>:SUMMary:EVM:UCCH[:AVERage]:RESult?.....	132
CALCulate<n>:LIMit<k>:SUMMary:EVM:UPRA[:AVERage]:RESult?.....	132
CALCulate<n>:LIMit<k>:SUMMary:EVM:USQP[:AVERage]:RESult?.....	133
CALCulate<n>:LIMit<k>:SUMMary:EVM:USSF[:AVERage]:RESult?.....	133
CALCulate<n>:LIMit<k>:SUMMary:EVM:USST[:AVERage]:RESult?.....	133
CALCulate<n>:LIMit<k>:SUMMary:FERRor:MAXimum:RESult.....	134
CALCulate<n>:LIMit<k>:SUMMary:FERRor[:AVERage]:RESult?.....	134
CALCulate<n>:LIMit<k>:SUMMary:GIMBalance:MAXimum:RESult.....	134
CALCulate<n>:LIMit<k>:SUMMary:GIMBalance[:AVERage]:RESult?.....	134
CALCulate<n>:LIMit<k>:SUMMary:IQOffset:MAXimum:RESult.....	134
CALCulate<n>:LIMit<k>:SUMMary:IQOffset[:AVERage]:RESult?.....	134
CALCulate<n>:LIMit<k>:SUMMary:QUADerror:MAXimum:RESult.....	135
CALCulate<n>:LIMit<k>:SUMMary:QUADerror[:AVERage]:RESult?.....	135
CALCulate<n>:LIMit<k>:SUMMary:SERRor:MAXimum:RESult.....	135
CALCulate<n>:LIMit<k>:SUMMary:SERRor[:AVERage]:RESult?.....	135

CALCulate<n>:LIMit<k>:SUMMary:EVM[:ALL]:MAXimum:RESult
CALCulate<n>:LIMit<k>:SUMMary:EVM[:ALL][:AVERage]:RESult?

This command queries the results of the EVM limit check of all resource elements.

Return values:

<LimitCheck> The type of limit (average or maximum) that is queried depends on the last syntax element.

FAILED

Limit check has failed.

PASSED

Limit check has passed.

NOTEVALUATED

Limits have not been evaluated.

Example:

CALC : LIM : SUMM : EVM : RES ?

Queries the limit check.

Usage:

Query only

**CALCulate<n>:LIMit<k>:SUMMary:EVM:PCHannel:MAXimum:RESult
CALCulate<n>:LIMit<k>:SUMMary:EVM:PCHannel[:AVERAge]:RESult?**

This command queries the results of the EVM limit check of all physical channel resource elements.

Return values:

<LimitCheck> The type of limit (average or maximum) that is queried depends on the last syntax element.

FAILED

Limit check has failed.

PASSED

Limit check has passed.

NOTEVALUATED

Limits have not been evaluated.

Example:

`CALC:LIM:SUMM:EVM:PCH:RES?`
Queries the limit check.

Usage:

Query only

**CALCulate<n>:LIMit<k>:SUMMary:EVM:PSIGnal:MAXimum:RESult
CALCulate<n>:LIMit<k>:SUMMary:EVM:PSIGnal[:AVERAge]:RESult?**

This command queries the results of the EVM limit check of all physical signal resource elements.

Return values:

<LimitCheck> The type of limit (average or maximum) that is queried depends on the last syntax element.

FAILED

Limit check has failed.

PASSED

Limit check has passed.

NOTEVALUATED

Limits have not been evaluated.

Example:

`CALC:LIM:SUMM:EVM:PSIG:RES?`
Queries the limit check.

Usage:

Query only

CALCulate<n>:LIMit<k>:SUMMary:EVM:SDQP[:AVERAge]:RESult?

This command queries the results of the EVM limit check of all PUSCH DMRS resource elements with a QPSK modulation.

Return values:

<LimitCheck>

FAILED

Limit check has failed.

PASSED

Limit check has passed.

NOTEVALUATED

Limits have not been evaluated.

Example:

CALC:LIM:SUMM:EVM:SDQP:RES?

Queries the limit check.

Usage:

Query only

CALCulate<n>:LIMit<k>:SUMMary:EVM:SDSF[:AVERAge]:RESult?

This command queries the results of the EVM limit check of all PUSCH DMRS resource elements with a 64QAM modulation.

Return values:

<LimitCheck>

FAILED

Limit check has failed.

PASSED

Limit check has passed.

NOTEVALUATED

Limits have not been evaluated.

Example:

CALC:LIM:SUMM:EVM:SDSF:RES?

Queries the limit check.

Usage:

Query only

CALCulate<n>:LIMit<k>:SUMMary:EVM:SDST[:AVERAge]:RESult?

This command queries the results of the EVM limit check of all PUSCH DMRS resource elements with a 16QAM modulation.

Return values:

<LimitCheck>

FAILED

Limit check has failed.

PASSED

Limit check has passed.

NOTEVALUATED

Limits have not been evaluated.

Example:

CALC:LIM:SUMM:EVM:SDST:RES?

Queries the limit check.

Usage:

Query only

CALCulate<n>:LIMit<k>:SUMMary:EVM:UCCD[:AVERage]:RESult?

This command queries the results of the EVM limit check of all PUCCH DMRS resource elements.

Return values:

<LimitCheck> **FAILED**
Limit check has failed.

PASSED
Limit check has passed.

NOTEVALUATED
Limits have not been evaluated.

Example:

`CALC:LIM:SUMM:EVM:UCCD:RES?`
Queries the limit check.

Usage:

Query only

CALCulate<n>:LIMit<k>:SUMMary:EVM:UCCH[:AVERage]:RESult?

This command queries the results of the EVM limit check of all PUCCH resource elements.

Return values:

<LimitCheck> **FAILED**
Limit check has failed.

PASSED
Limit check has passed.

NOTEVALUATED
Limits have not been evaluated.

Example:

`CALC:LIM:SUMM:EVM:UCCH:RES?`
Queries the limit check.

Usage:

Query only

CALCulate<n>:LIMit<k>:SUMMary:EVM:UPRA[:AVERage]:RESult?

This command queries the results of the EVM limit check of all PRACH resource elements.

Return values:

<LimitCheck> **FAILED**
Limit check has failed.

PASSED
Limit check has passed.

NOTEVALUATED
Limits have not been evaluated.

Example:

`CALC:LIM:SUMM:EVM:UPRA:RES?`
Queries the limit check.

Usage: Query only

CALCulate<n>:LIMit<k>:SUMMary:EVM:USQP[:AVERage]:RESult?

This command queries the results of the EVM limit check of all PUSCH resource elements with a QPSK modulation

Return values:

<LimitCheck> **FAILED**
Limit check has failed.

PASSED
Limit check has passed.

NOTEVALUATED
Limits have not been evaluated.

Example: `CALC:LIM:SUMM:EVM:USQP:RES?`
Queries the limit check.

Usage: Query only

CALCulate<n>:LIMit<k>:SUMMary:EVM:USSF[:AVERage]:RESult?

This command queries the results of the EVM limit check of all PUSCH resource elements with a 64QAM modulation.

Return values:

<LimitCheck> **FAILED**
Limit check has failed.

PASSED
Limit check has passed.

NOTEVALUATED
Limits have not been evaluated.

Example: `CALC:LIM:SUMM:EVM:USSF:RES?`
Queries the limit check.

Usage: Query only

CALCulate<n>:LIMit<k>:SUMMary:EVM:USST[:AVERage]:RESult?

This command queries the results of the EVM limit check of all PUSCH resource elements with a 16QAM modulation.

Return values:

<LimitCheck> **FAILED**
Limit check has failed.

PASSED
Limit check has passed.

NOTEVALUATED
Limits have not been evaluated.

Example: `CALC:LIM:SUMM:EVM:USST:RES?`
Queries the limit check.

Usage: Query only

CALCulate<n>:LIMit<k>:SUMMary:FERRor:MAXimum:RESult
CALCulate<n>:LIMit<k>:SUMMary:FERRor[:AVERage]:RESult?

This command queries the result of the frequency error limit check.

Return values:

<LimitCheck> The type of limit (average or maximum) that is queried depends on the last syntax element.

FAILED

Limit check has failed.

PASSED

Limit check has passed.

NOTEVALUATED

Limits have not been evaluated.

Example: `CALC:LIM:SUMM:SERR:RES?`
Queries the limit check.

Usage: Query only

CALCulate<n>:LIMit<k>:SUMMary:GIMBalance:MAXimum:RESult
CALCulate<n>:LIMit<k>:SUMMary:GIMBalance[:AVERage]:RESult?

This command queries the result of the gain imbalance limit check.

Return values:

<LimitCheck> The type of limit (average or maximum) that is queried depends on the last syntax element.

FAILED

Limit check has failed.

PASSED

Limit check has passed.

NOTEVALUATED

Limits have not been evaluated.

Example: `CALC:LIM:SUMM:GIMB:RES?`
Queries the limit check.

Usage: Query only

CALCulate<n>:LIMit<k>:SUMMary:IQOFFset:MAXimum:RESult
CALCulate<n>:LIMit<k>:SUMMary:IQOFFset[:AVERage]:RESult?

This command queries the result of the I/Q offset limit check.

Return values:

<LimitCheck>

The type of limit (average or maximum) that is queried depends on the last syntax element.

FAILED

Limit check has failed.

PASSED

Limit check has passed.

NOTEVALUATED

Limits have not been evaluated.

Example:

```
CALC:LIM:SUMM:IQOF:MAX:RES?
```

Queries the limit check.

Usage:

Query only

CALCulate<n>:LIMit<k>:SUMMary:QUADerror:MAXimum:RESult

CALCulate<n>:LIMit<k>:SUMMary:QUADerror[:AVERage]:RESult?

This command queries the result of the quadrature error limit check.

Return values:

<LimitCheck>

The type of limit (average or maximum) that is queried depends on the last syntax element.

FAILED

Limit check has failed.

PASSED

Limit check has passed.

NOTEVALUATED

Limits have not been evaluated.

Example:

```
CALC:LIM:SUMM:QUAD:RES?
```

Queries the limit check.

Usage:

Query only

CALCulate<n>:LIMit<k>:SUMMary:SERRor:MAXimum:RESult

CALCulate<n>:LIMit<k>:SUMMary:SERRor[:AVERage]:RESult?

This command queries the results of the sampling error limit check.

Return values:

<LimitCheck>

The type of limit (average or maximum) that is queried depends on the last syntax element.

FAILED

Limit check has failed.

PASSED

Limit check has passed.

NOTEVALUATED

Limits have not been evaluated.

Example: `CALC:LIM:SUMM:SERR:RES?`
 Queries the limit check.

Usage: Query only

7.10 Remote Commands to Configure the Application

7.10.1 General Configuration

The following remote control command control general configuration of the application.

The remote control commands to select the result displays for I/Q measurements are described in [chapter 7.5, "Working with Windows in the Display"](#), on page 95.

CONFigure[LTE]:MEASurement	136
MMEMory:LOAD:IQ:STATe	137
SYSTem:PRESet:CHANnel[:EXECute]	137

CONFigure[LTE]:MEASurement <Measurement>

This command selects the measurement.

Parameters:

- <Measurement>** **ACLR**
 Selects the Adjacent Channel Leakage Ratio measurement.
- ESpectrum**
 Selects the Spectrum Emission Mask measurement.
- EVM**
 Selects I/Q measurements with the "EVM" display configuration.
- MCAClr**
 Selects Multi-Carrier ACLR measurement.
- MCESpectrum**
 Selects Multi-Carrier SEM measurement.
- TAERor**
 Selects the Time Alignment Error measurement.
- TPOO**
 Selects the Transmit On/Off Power measurement.

Example: `CONF:MEAS ACLR`
 Selects the ACLR measurement.

Manual operation: See "[ACLR](#)" on page 26
 See "[Spectrum Mask](#)" on page 27
 See "[Multi Carrier ACLR](#)" on page 28

MMEMory:LOAD:IQ:STATe <Path>

This command restores I/Q data from a file.

Setting parameters:

<Path> String containing the path and name of the source file.

Example: MMEM:LOAD:IQ:STAT 'C:
 \R_S\Instr\user\data.iq.tar'
 Loads I/Q data from the specified file.

Usage: Setting only

SYSTem:PRESet:CHANnel[:EXECute]

This command restores the default instrument settings in the current channel.

Use `INST:SEL` to select the channel.

Example: INST 'Spectrum2'
 Selects the channel for "Spectrum2".
 SYST:PRESet:CHAN:EXEC
 Restores the factory default settings to the "Spectrum2" channel.

Usage: Event

Manual operation: See "Preset Channel" on page 41

7.10.2 Configuring I/Q Measurements

- [Signal Description](#)..... 137
- [Input / Frontend](#)..... 159
- [Signal Capture](#)..... 166
- [Demodulation](#)..... 170
- [Tracking](#)..... 173

7.10.2.1 Signal Description

- [Signal Characteristics](#)..... 138
- [MIMO Configuration](#)..... 142
- [Subframe Configuration](#)..... 143
- [Global Settings](#)..... 147
- [Demodulation Reference Signal](#)..... 148
- [Sounding Reference Signal](#)..... 150
- [PUSCH Structure](#)..... 153
- [PUCCH Structure](#)..... 154
- [PRACH Structure](#)..... 156

Signal Characteristics

CONFigure[:LTE]:DUPLexing.....	138
CONFigure[:LTE]:LDIRection.....	138
CONFigure[:LTE]:UL[:CC<cci>]:BW.....	138
CONFigure[:LTE]:UL[:CC<cci>]:CYCPrefix.....	139
CONFigure[:LTE]:UL[:CC<cci>]:PLC:CID.....	139
CONFigure[:LTE]:UL[:CC<cci>]:PLC:CIDGroup.....	140
CONFigure[:LTE]:UL[:CC<cci>]:PLC:PLID.....	140
CONFigure[:LTE]:UL[:CC<cci>]:TDD:SPSC.....	140
CONFigure[:LTE]:UL[:CC<cci>]:TDD:UDConf.....	140
MMEMory:LOAD:DEModsetting.....	141
MMEMory:LOAD:TMOD:DL.....	141
[SENSe][:LTE]:SFLatness:ECONditions.....	142
[SENSe][:LTE]:SFLatness:OBANd.....	142

CONFigure[:LTE]:DUPLexing <Duplexing>

This command selects the duplexing mode.

Parameters:

<Duplexing>	TDD Time division duplex
	FDD Frequency division duplex
	*RST: FDD

Example: CONF:DUPL TDD
Activates time division duplex.

Manual operation: See "Selecting the LTE Mode" on page 42

CONFigure[:LTE]:LDIRection <Direction>

This command selects the link direction

Parameters:

<Direction>	DL Downlink
	UL Uplink

Example: CONF:LDIR DL
EUTRA/LTE option is configured to analyze downlink signals.

Manual operation: See "Selecting the LTE Mode" on page 42

CONFigure[:LTE]:UL[:CC<cci>]:BW <Bandwidth>

This command selects the channel bandwidth.

Parameters:	
<Bandwidth>	BW1_40 BW3_00 BW5_00 BW10_00 BW15_00 BW20_00
Example:	Single carrier measurement: CONF:UL:BW BW1_40 Defines a channel bandwidth of 1.4 MHz.
Example:	Aggregated carrier measurement: CONF:UL:CC1:BW BW5_00 Defines a channel bandwidth of 5 MHz for the first carrier.
Manual operation:	See " Channel Bandwidth / Number of Resource Blocks " on page 43 See " Remote commands to configure carrier aggregation " on page 77

CONFigure[:LTE]:UL[:CC<cci>]:CYCPrefix <PrefixLength>

This command selects the cyclic prefix.

Parameters:	
<PrefixLength>	NORM Normal cyclic prefix length EXT Extended cyclic prefix length AUTO Automatic cyclic prefix length detection *RST: AUTO
Example:	Single carrier measurements: CONF:UL:CYCP EXT Selects an extended cyclic prefix.
Example:	Aggregated carrier measurements: CONF:UL:CC1:CYCP EXT Selects an extended cyclic prefix for the first carrier.
Manual operation:	See " Cyclic Prefix " on page 44

CONFigure[:LTE]:UL[:CC<cci>]:PLC:CID <CellId>

This command defines the cell ID.

Parameters:	
<CellId>	AUTO Automatically defines the cell ID. <numeric value> Number of the cell ID. Range: 0 to 503

Example: `CONF:UL:PLC:CID AUTO`
Automatically detects the cell ID.

Manual operation: See ["Configuring the Physical Layer Cell Identity"](#) on page 45

CONFigure[:LTE]:UL[:CC<cci>]:PLC:CIDGroup <GroupNumber>

This command selects the cell identity group for uplink signals.

Parameters:

<GroupNumber> Range: 1 to 167
 *RST: 0

Example: `CONF:UL:PLCI:CIDG 12`
Selects cell identity group 12.

Manual operation: See ["Configuring the Physical Layer Cell Identity"](#) on page 45

CONFigure[:LTE]:UL[:CC<cci>]:PLC:PLID <Identity>

This command selects the physical layer identity for uplink signals.

Parameters:

<Identity> **0...2**
 Manual selection
 *RST: AUTO

Example: `CONF:DL:PLC:PLID 2`
Sets the physical layer identity to 2.

Manual operation: See ["Configuring the Physical Layer Cell Identity"](#) on page 45

CONFigure[:LTE]:UL[:CC<cci>]:TDD:SPSC <Configuration>

This command selects the special TDD subframe configuration.

Parameters:

<Configuration> <numeric value>

Example: Single carrier measurements:
`CONF:UL:TDD:SPSC 2`
Selects special subframe configuration 2.

Example: Carrier aggregation measurements:
`CONF:UL:CC1:TDD:SPSC 2`
Selects special subframe configuration 2 for the first carrier.

Manual operation: See ["Configuring TDD Frames"](#) on page 44

CONFigure[:LTE]:UL[:CC<cci>]:TDD:UDConf <Configuration>

This command selects the subframe configuration for TDD signals.

Parameters:

<Configuration> Range: 0 to 6
*RST: 0

Example:

Single carrier measurements:
CONF:UL:TDD:UDC 4
Selects allocation configuration number 4.

Example:

Carrier aggregation measurements:
CONF:UL:CC1:TDD:UDC 4
Selects allocation configuration number 4 for the first carrier.

Manual operation: See "[Configuring TDD Frames](#)" on page 44

MMEMory:LOAD:DEModsetting <Path>

This command restores previously saved demodulation settings.

The file must be of type "*.allocation" and depends on the link direction that was currently selected when the file was saved. You can load only files with correct link directions.

Setting parameters:

<Path> String containing the path and name of the file.

Example: MMEM:LOAD:DEM 'D:\USER\Settingsfile.allocation'

Usage: Setting only

MMEMory:LOAD:TMOD:DL <TestModel>

This command loads an EUTRA test model (E-TM).

The test models are in accordance with 3GPP TS 36.141.

Setting parameters:

<TestModel> **'E-TM1_1_20MHz'**
EUTRA Test Model 1.1 (E-TM1.1)
'E-TM1_2_20MHz'
EUTRA Test Model 1.2 (E-TM1.2)
'E-TM2_20MHz'
EUTRA Test Model 2 (E-TM2)
'E-TM3_1_20MHz'
EUTRA Test Model 3.1 (E-TM3.1)
'E-TM3_2_20MHz'
EUTRA Test Model 3.2 (E-TM3.2)
'E-TM3_3_20MHz'
EUTRA Test Model 3.3 (E-TM3.3)
To select a test model for a different bandwidth, replace "20MHz" with either "1_4MHz", "3MHz", "5MHz", "10MHz" or "15MHz".

Example: `M MEM:LOAD:TMOD:DL 'E-TM2__10MHz'`
 Selects test model 2 for a 10 MHz bandwidth.

Usage: Setting only

[SENSe][:LTE]:SFLatness:ECONditions <State>

This command turns extreme conditions for spectrum flatness measurements on and off.

Parameters:
 <State> ON | OFF
 *RST: OFF

Example: `SFL:ECON ON`
 Turns extreme conditions on.

Manual operation: See ["Extreme Conditions"](#) on page 46

[SENSe][:LTE]:SFLatness:OBANd <NofSubbands>

This command selects the operating band for spectrum flatness Measurements.

Parameters:
 <NofSubbands> <numeric value>
 Range: 1 to 40
 *RST: 1

Example: `SFL:OBAN 10`
 Selects operating band 10.

Manual operation: See ["Operating Band Index"](#) on page 46

MIMO Configuration

[CONFigure\[:LTE\]:UL:MIMO:ASELction.....](#) 142

CONFigure[:LTE]:UL:MIMO:ASELction <Antenna>

This command selects the antenna for measurements with MIMO setups.

Parameters:
 <Antenna> **ANT1 | ANT2 | ANT3 | ANT4**
 Select a single antenna to be analyzed
ALL
 Select all antennas to be analyzed

Example: `CONF:UL:MIMO:ASEL ANT2`
 Selects antenna 2 to be analyzed.

Manual operation: See ["MIMO Configuration"](#) on page 46

Subframe Configuration

CONFigure[:LTE]:UL:CSUBframes.....	143
CONFigure[:LTE]:UL[:CC<cci>]:SUBFrame<subframe>:ALLoc:CONT.....	143
CONFigure[:LTE]:UL[:CC<cci>]:SUBFrame<subframe>:ALLoc:MODulation.....	144
CONFigure[:LTE]:UL[:CC<cci>]:SUBFrame<subframe>:ALLoc:PRECoding:CBINdex.....	144
CONFigure[:LTE]:UL[:CC<cci>]:SUBFrame<subframe>:ALLoc:PRECoding:CLMapping.....	144
CONFigure[:LTE]:UL[:CC<cci>]:SUBFrame<subframe>:ALLoc:PUCCh:FORMat.....	144
CONFigure[:LTE]:UL[:CC<cci>]:SUBFrame<subframe>:ALLoc:PUCCh:NPAr.....	145
CONFigure[:LTE]:UL[:CC<cci>]:SUBFrame<subframe>:ALLoc:PUSCh:CSField.....	145
CONFigure[:LTE]:UL[:CC<cci>]:SUBFrame<subframe>:ALLoc:PUSCh:NDMRs.....	146
CONFigure[:LTE]:UL[:CC<cci>]:SUBFrame<subframe>:ALLoc:RATo.....	146
CONFigure[:LTE]:UL[:CC<cci>]:SUBFrame<subframe>:ALLoc[:CLUSter<cluster>]: RBCount.....	146
CONFigure[:LTE]:UL[:CC<cci>]:SUBFrame<subframe>:ALLoc[:CLUSter<cluster>]: RBOFset.....	146
[SENSe][:LTE]:UL:DEMod:ACON.....	147
[SENSe][:LTE]:UL:FORMat:SCD.....	147

CONFigure[:LTE]:UL:CSUBframes <NofSubframes>

This command selects the number of configurable subframes in the uplink signal.

Parameters:

<NofSubframes> Range: 1 to 10
 *RST: 1

Example:

CONF:UL:CSUB 5
Sets the number of configurable subframes to 5.

CONFigure[:LTE]:UL[:CC<cci>]:SUBFrame<subframe>:ALLoc:CONT <Content>

This command allocates a PUCCH or PUSCH to an uplink allocation.

Parameters:

<Content> **NONE**
 Turns off the PUSCH and the PUCCH.

PUCCh
 Turns on the PUCCH.

PUSCh
 Turns on the PUSCH.

PSCC
 Turns on the PUCCH as well as the PUSCH.

 *RST: PUSC

Example:

CONF:UL:SUBF8:ALL:CONT PUCCh
Subframe 8 contains a PUCCH.

Manual operation:

See "Enable PUCCH" on page 49
See "Enable PUSCH" on page 49

CONFigure[:LTE]:UL[:CC<cci>]:SUBFrame<subframe>:ALLoc:MODulation
 <Modulation>

This command selects the modulation of an uplink allocation.

Parameters:

<Modulation> QPSK | QAM16 | QAM64
 *RST: QPSK

Example:

CONF:UL:SUBF8:ALL:MOD QPSK
 The modulation of the allocation in subframe 8 is QPSK.

Manual operation: See "[Modulation](#)" on page 49

CONFigure[:LTE]:UL[:CC<cci>]:SUBFrame<subframe>:ALLoc:PRECoding:
CBIndex <CBIndex>

This command selects the codebook index for a PUSCH allocation.

Parameters:

<CBIndex> Range: 0 to 5
 *RST: 0

Example:

CONF:UL:SUBF:ALL:PREC:CBIN 1
 Selects codebook index 1 for the PUSCH allocation.

Manual operation: See "[Enhanced PUSCH Configuration](#)" on page 50

CONFigure[:LTE]:UL[:CC<cci>]:SUBFrame<subframe>:ALLoc:PRECoding:
CLMapping <Mapping>

This command selects the codeword to layer mapping for a PUSCH allocation.

Parameters:

<Mapping> LC11 | LC21 | LC22

Example:

CONF:UL:SUBF2:ALL:PREC:CLM LC11
 Assigns codeword-to-layer mapping 1/1 to subframe 2.

Manual operation: See "[Enhanced PUSCH Configuration](#)" on page 50

CONFigure[:LTE]:UL[:CC<cci>]:SUBFrame<subframe>:ALLoc:PUCCh:FORMat
 <Format>

This command selects the PUCCH format for a particular subframe.

The command is available if you have selected PUCCH format selection on subframe basis with [CONFigure\[:LTE\]:UL:PUCCh:FORMat](#).

Parameters:

<Format> **F1N (F1 normal)**
 F1S (F1 shortened)
 F1AN (F1a normal)
 F1AS (F1a shortened)
 F1BN (F1b normal)
 F1BS (F1b shortened)
 F2 (F2)
 F2A (F2a)
 F2B (F2b)
 F3 (F3)

Example:

`CONF:UL:SUBF4:ALL:PUCCH:FORM F3`
 Selects format F3 for the PUCCH in subframe 4.

Manual operation: See "[Enhanced PUCCH Configuration](#)" on page 51

CONFigure[:LTE]:UL[:CC<cci>]:SUBFrame<subframe>:ALLoc:PUCCh:NPAr
 <Parameter>

This command defines N_PUCCH on a subframe basis.

The command is available if [CONFigure\[:LTE\]:UL:PUCCh:NPAr](#) on page 156 is turned on.

Parameters:

<Parameter> <numeric value>

Example:

`CONF:UL:SUBF:ALL:PUCCH:NPAr 2`
 Sets N_PUCCH to 2.

Manual operation: See "[Enhanced PUCCH Configuration](#)" on page 51

CONFigure[:LTE]:UL[:CC<cci>]:SUBFrame<subframe>:ALLoc:PUSCh:CSField
 <CyclicShiftField>

This command defines the cyclic shift field of the demodulation reference signal.

Available if [CONFigure\[:LTE\]:UL\[:CC<cci>\]:DRS:AOCc](#) on page 148 has been turned on.

Parameters:

<CyclicShiftField> Range: 0 to 7
 *RST: 0

Example:

`CONF:UL:SUBF:ALL:PUSCH:CSF 4`
 Defines cyclic shift field 4.

Manual operation: See "[Enhanced Demodulation Reference Signal Configuration](#)" on page 51

CONFigure[:LTE]:UL[:CC<cci>]:SUBFrame<subframe>:ALLoc:PUSCh:NDMRs
 <PuschNDMRS>

This command defines the part of the DMRS index that is used for the uplink scheduling assignment.

Parameters:

<PuschNDMRS> <numeric value>
 Range: 0 to 11
 *RST: 0

Example: CONF:UL:SUBF:ALL:PUSC:NDMR 2
 Defines index 2.

Manual operation: See ["Enhanced Demodulation Reference Signal Configuration"](#) on page 51

CONFigure[:LTE]:UL[:CC<cci>]:SUBFrame<subframe>:ALLoc:RATO <State>

This command turns the resource allocation type 1 on and off.

Parameters:

<State> ON | OFF
 *RST: OFF

Example: CONF:UL:SUBF:ALL:RATO ON
 Turns resource allocation type 1 on.

Manual operation: See ["Enhanced PUSCH Configuration"](#) on page 50

CONFigure[:LTE]:UL[:CC<cci>]:SUBFrame<subframe>:ALLoc[:
CLUSter<cluster>]:RBCount <ResourceBlocks>

This command selects the number of resource blocks in an uplink subframe.

Parameters:

<NofRBs> <numeric value>
 *RST: 11

Example: CONF:UL:SUBF8:ALL:RBC 8
 Subframe 8 consists of 8 resource blocks.

Manual operation: See ["Number of RB"](#) on page 50

CONFigure[:LTE]:UL[:CC<cci>]:SUBFrame<subframe>:ALLoc[:
CLUSter<cluster>]:RBOffset <Offset>

This command defines the resource block offset in an uplink subframe.

Parameters:

<RBOffset> <numeric value>
 *RST: 2

Example: `CONF:UL:SUBF8:ALL:RBOF 5`
Subframe 8 has a resource block offset of 5.

Manual operation: See ["Offset RB"](#) on page 50

`[SENSe][:LTE]:UL:DEMod:ACON <Type>`

This command selects the method of automatic demodulation for uplink signals.

Parameters:

<Type> **ALL**
Automatically detects and demodulates the PUSCH and SRS.

OFF
Automatic demodulation is off.

SCON
Automatically detects and demodulates the values available in the subframe configuration table.

Example: `UL:DEM:ACON OFF`
Turns automatic demodulation off.

Manual operation: See ["Auto Demodulation"](#) on page 48

`[SENSe][:LTE]:UL:FORMat:SCD <State>`

This command turns detection of the subframe configuration on and off.

The command is available if "Auto Demodulation" is turned off.

Parameters:

<State> ON | OFF

*RST: OFF

Example: `UL:FORM:SCD ON`
Turns detection of the subframe configuration on.

Manual operation: See ["Subframe Configuration Detection"](#) on page 48

Global Settings

[CONFigure\[:LTE\]:UL:SFNO](#)..... 147

[CONFigure\[:LTE\]:UL:UEID](#)..... 148

`CONFigure[:LTE]:UL:SFNO <Offset>`

This command defines the system frame number offset.

The application uses the offset to demodulate the frame.

Parameters:

<Offset> <numeric value>

*RST: 0

Example: `CONF:UL:SFNO 2`
Selects frame number offset 2.

Manual operation: See "[Frame Number Offset](#)" on page 52

CONFigure[:LTE]:UL:UEID <ID>

Sets the radio network temporary identifier (RNTI) of the UE.

Parameters:

<ID> <numeric value>
*RST: 0

Example: `CONF:UL:UEID 2`
Sets the UE ID to 2.

Manual operation: See "[UE ID/n_RNTI](#)" on page 52

Demodulation Reference Signal

CONFigure[:LTE]:UL[:CC<cci>]:DRS:AOCc	148
CONFigure[:LTE]:UL[:CC<cci>]:DRS:DSSHift	148
CONFigure[:LTE]:UL[:CC<cci>]:DRS:GRPHopping	149
CONFigure[:LTE]:UL[:CC<cci>]:DRS:NDMRs	149
CONFigure[:LTE]:UL[:CC<cci>]:DRS:PUCCh:POWer	149
CONFigure[:LTE]:UL[:CC<cci>]:DRS[:PUSCh]:POWer	149
CONFigure[:LTE]:UL[:CC<cci>]:DRS:SEQHopping	149

CONFigure[:LTE]:UL[:CC<cci>]:DRS:AOCc <State>

This command turns the configuration of the demodulation reference signal on a sub-frame basis via the "Cyclic Field Shift" on and off.

Parameters:

<State> ON | OFF

Example: `CONF:UL:DRS:AOCc ON`
Turns Activate-DMRS-with OCC on.

Manual operation: See "[Activate-DMRS-With OCC](#)" on page 54

CONFigure[:LTE]:UL[:CC<cci>]:DRS:DSSHift <Shift>

This command selects the delta sequence shift of the uplink signal.

Parameters:

<Shift> <numeric value>
*RST: 0

Example: `CONF:UL:DRS:DSSH 3`
Sets the delta sequence shift to 3.

Manual operation: See "[Delta Sequence Shift](#)" on page 54

CONFigure[:LTE]:UL[:CC<cci>]:DRS:GRPHopping <State>

This command turns group hopping for uplink signals on and off.

Parameters:

<State> ON | OFF
 *RST: OFF

Example: CONF:UL:DRS:GRPHopping ON
 Activates group hopping.

Manual operation: See "[Group Hopping](#)" on page 53

CONFigure[:LTE]:UL[:CC<cci>]:DRS:NDMRs <nDMRS>

This command defines the n_{DMRS} .

Parameters:

<nDMRS> <numeric value>

Example: CONF:UL:DRS:NDMR 0
 Selects n_{DMRS} 0.

Manual operation: See "[n\(1\)_DMRS](#)" on page 54

CONFigure[:LTE]:UL[:CC<cci>]:DRS:PUCCh:POWER <Power>

This command sets the relative power of the PUCCH.

Parameters:

<Power> *RST: 0
 Default unit: DB

Example: CONF:UL:DRS:PUCCh:POW 2
 Sets the power of the PUCCH to 2 dB.

Manual operation: See "[Relative Power PUCCH](#)" on page 54

CONFigure[:LTE]:UL[:CC<cci>]:DRS[:PUSCh]:POWER <Power>

This command sets the relative power of the PUSCH.

Parameters:

<Power> *RST: 0
 Default unit: DB

Example: CONF:UL:DRS:POW 2
 Sets the relative power of the PUSCH to 2 dB.

Manual operation: See "[Relative Power PUSCH](#)" on page 53

CONFigure[:LTE]:UL[:CC<cci>]:DRS:SEQHopping <State>

This command turns sequence hopping for uplink signals on and off.

Parameters:

<State> ON | OFF
 *RST: OFF

Example:

CONF:UL:DRS:SEQH ON
 Activates sequence hopping.

Manual operation: See " [Sequence Hopping](#)" on page 54

Sounding Reference Signal

CONFigure[LTE]:UL:SRS:ANST.....	150
CONFigure[LTE]:UL:SRS:BHOP.....	150
CONFigure[LTE]:UL:SRS:BSRS.....	151
CONFigure[LTE]:UL:SRS:CSRS.....	151
CONFigure[LTE]:UL:SRS:CYCS.....	151
CONFigure[LTE]:UL:SRS:ISRS.....	151
CONFigure[LTE]:UL:SRS:MUPT.....	152
CONFigure[LTE]:UL:SRS:NRRC.....	152
CONFigure[LTE]:UL:SRS:POWER.....	152
CONFigure[LTE]:UL:SRS:STAT.....	152
CONFigure[LTE]:UL:SRS:SUConfig.....	153
CONFigure[LTE]:UL:SRS:TRComb.....	153

CONFigure[LTE]:UL:SRS:ANST <State>

This command turns simultaneous transmission of the Sounding Reference Signal (SRS) and ACK/NACK messages (via PUCCH) on and off.

Simultaneous transmission works only if the PUCCH format ist either 1, 1a, 1b or 3.

Parameters:

<State> **ON**
 Allows simultaneous transmission of SRS and PUCCH.
OFF
 SRS not transmitted in the subframe for which you have configured simultaneous transmission of PUCCH and SRS.

Example:

CONF:UL:SRS:ANST ON
 Turns simultaneous transmission of the SRS and PUCCH in one subframe on.

Manual operation: See "[A/N + SRS Simultaneous TX](#)" on page 58

CONFigure[LTE]:UL:SRS:BHOP <Bandwidth>

This command defines the frequency hopping bandwidth b_{hop} .

Parameters:

<Bandwidth> <numeric value>
 *RST: 0

Example: `CONF:UL:SRS:BHOP 1`
Sets the frequency hopping bandwidth to 1.

Manual operation: See "[Hopping BW b_hop](#)" on page 56

CONFigure[LTE]:UL:SRS:BSRS <Bandwidth>

This command defines the bandwidth of the SRS (B_{SRS}).

Parameters:
<Bandwidth> <numeric value>
*RST: 0

Example: `CONF:UL:SRS:BSRS 1`
Sets the SRS bandwidth to 1.

Manual operation: See "[SRS Bandwidth B_SRS](#)" on page 56

CONFigure[LTE]:UL:SRS:CSRS <Configuration>

This command defines the SRS bandwidth configuration (C_{SRS}).

Parameters:
<Configuration> <numeric value>
*RST: 0

Example: `CONF:UL:SRS:CSRS 2`
Sets the SRS bandwidth configuration to 2.

Manual operation: See "[SRS BW Conf. C_SRS](#)" on page 57

CONFigure[LTE]:UL:SRS:CYCS <CyclicShift>

Sets the cyclic shift n_{CS} used for the generation of the sounding reference signal CAZAC sequence.

Parameters:
<CyclicShift> <numeric value>
*RST: 0

Example: `CONF:UL:SRS:CYCS 2`
Sets the cyclic shift to 2.

Manual operation: See "[SRS Cyclic Shift N_CS](#)" on page 56

CONFigure[LTE]:UL:SRS:ISRS <ConfIndex>

This command defines the SRS configuration index (I_{SRS}).

Parameters:
<ConfIndex> <numeric value>
*RST: 0

Example: `CONF:UL:SRS:ISRS 1`
Sets the configuration index to 1.

Manual operation: See "[Conf. Index I_SRS](#)" on page 57

CONFigure[:LTE]:UL:SRS:MUPT <State>

This command turns SRS MaxUpPts on and off.

Parameters:
<State> ON | OFF
*RST: OFF

Manual operation: See "[SRS MaxUpPts](#)" on page 56

CONFigure[:LTE]:UL:SRS:NRRC <FreqDomPos>

Sets the UE specific parameter Freq. Domain Position n_{RRC} .

Parameters:
<FreqDomPos> <numeric value>
*RST: 0

Example: `CONF:UL:SRS:NRRC 1`
Sets n_{RRC} to 1.

Manual operation: See "[Freq. Domain Pos. \$n_{\text{RRC}}\$](#) " on page 57

CONFigure[:LTE]:UL:SRS:POWer <Power>

Defines the relative power of the sounding reference signal.

Parameters:
<Power> <numeric value>
*RST: 0
Default unit: DB

Example: `CONF:UL:SRS:POW -1.2`
Sets the power to -1.2 dB.

Manual operation: See "[SRS Rel Power](#)" on page 57

CONFigure[:LTE]:UL:SRS:STAT <State>

Activates or deactivates the sounding reference signal.

Parameters:
<State> ON | OFF
*RST: OFF

Example: `CONF:UL:SRS:STAT ON`
Activates the sounding reference signal.

Manual operation: See "[Present](#)" on page 55

CONFigure[:LTE]:UL:SRS:SUConfig <Configuration>

This command defines the SRS subframe configuration.

Parameters:

<Configuration> <numeric value>
*RST: 0

Example: CONF:UL:SRS:SUC 4
Sets SRS subframe configuration to 4.

Manual operation: See "[SRS Subframe Conf.](#)" on page 56

CONFigure[:LTE]:UL:SRS:TRComb <TransComb>

This command defines the transmission comb (k_{TC}).

Parameters:

<TransComb> <numeric value>
*RST: 0

Example: CONF:UL:SRS:TRC 1
Sets transmission comb to 1.

Manual operation: See "[Transm. Comb. \$k_{TC}\$](#) " on page 57

PUSCH Structure

CONFigure[:LTE]:UL[:CC<cci>]:PUSCh:FHMode.....	153
CONFigure[:LTE]:UL[:CC<cci>]:PUSCh:FHOFFset.....	154
CONFigure[:LTE]:UL[:CC<cci>]:PUSCh:FHOP:IIHB.....	154
CONFigure[:LTE]:UL[:CC<cci>]:PUSCh:NOSM.....	154

CONFigure[:LTE]:UL[:CC<cci>]:PUSCh:FHMode <HoppingMode>

This command selects the frequency hopping mode in the PUSCH structure.

Parameters:

<HoppingMode> **NONE**
No hopping
INTer
Inter subframe hopping
INTRa
Intra subframe hopping
*RST: NONE

Example: CONF:UL:PUSC:FHM NONE
Deactivates frequency hopping for the PUSCH.

Manual operation: See "[Frequency Hopping Mode](#)" on page 58

CONFigure[:LTE]:UL[:CC<cci>]:PUSCh:FHOFFset <Offset>

This command defines the frequency hopping offset for the PUSCH.

Parameters:

<Offset> <numeric value>
*RST: 4

Example: CONF:UL:PUSCh:FHOFF 5
Sets the hopping offset to 5.

Manual operation: See "[PUSCH Hopping Offset](#)" on page 59

CONFigure[:LTE]:UL[:CC<cci>]:PUSCh:FHOP:IIHB <HBInfo>

This command defines the information in hopping bits of the PUSCH.

Parameters:

<HBInfo> <numeric value>
Range: 0 to 3
*RST: 0

Example: CONF:UL:PUSCh:FHOP:IIHB 1
Defines type 1 as the information in hopping bits.

Manual operation: See "[Info. in Hopping Bits](#)" on page 59

CONFigure[:LTE]:UL[:CC<cci>]:PUSCh:NOSM <NofSubbands>

This command defines the number of subbands/M of the PUSCH.

Parameters:

<NofSubbands> <numeric value>
*RST: 4

Example: CONF:UL:PUSCh:NOSM 2
Sets the number of subbands to 2.

Manual operation: See "[Number of Subbands](#)" on page 59

PUCCH Structure

CONFigure[:LTE]:UL:PUCCh:DESHift	154
CONFigure[:LTE]:UL:PUCCh:FORMat	155
CONFigure[:LTE]:UL:PUCCh:N1CS	155
CONFigure[:LTE]:UL:PUCCh:N2RB	155
CONFigure[:LTE]:UL:PUCCh:NORB	156
CONFigure[:LTE]:UL:PUCCh:NPAr	156

CONFigure[:LTE]:UL:PUCCh:DESHift <Shift>

This command defines the delta shift of the PUCCH.

Parameters:

<Shift> <numeric value>
 Range: 1 to 3
 *RST: 2

Example:

CONF:UL:PUCCH:DESH 3
 Sets the delta shift of the PUCCH to 3.

Manual operation: See "[Delta Shift](#)" on page 61

CONFigure[LTE]:UL:PUCCh:FORMat <Format>

This command selects the PUCCH format.

Note that formats 2a and 2b are available for normal cyclic prefix length only.

Parameters:

<Format> **F1 (F1)**
F1A (F1a)
F1B (F1b)
F2 (F2)
F2A (F2a)
F2B (F2b)
F3 (F3)
SUBF
 Allows you to define the PUCCH format for each subframe separately with .
 *RST: F1

Example:

CONF:UL:PUCCH:FORM F1B
 Sets the PUCCH format to F1B.

Manual operation: See "[Format](#)" on page 61

CONFigure[LTE]:UL:PUCCh:N1CS <N1cs>

This command defines the N(1)_cs of the PUCCH.

Parameters:

<N1cs> <numeric value>
 *RST: 6

Example:

CONF:UL:PUCCH:N1CS 4
 Sets N(1)_cs to 4.

Manual operation: See "[N\(1\)_cs](#)" on page 60

CONFigure[LTE]:UL:PUCCh:N2RB <N2RB>

This command defines the N(2)_RB of the PUCCH.

Parameters:

<N2RB> <numeric value>
 *RST: 1

Example:

CONF:UL:PUCCh:N2RB 2
 Sets N2_RB to 2.

Manual operation: See " [N\(2\)_RB](#)" on page 61

CONFigure[:LTE]:UL:PUCCh:NORB <ResourceBlocks>

This command selects the number of resource blocks for the PUCCH.

Parameters:

<ResourceBlocks> <numeric value>
 Selects the number of RBs.
AUTO
 Detects the number of RBs automatically.
 *RST: 0

Example:

CONF:UL:PUCCh:NORB 6
 Sets the number of resource blocks to 6.

Manual operation: See " [No. of RBs for PUCCH](#)" on page 60

CONFigure[:LTE]:UL:PUCCh:NPAR <Format>

This command defines the N_PUCCH parameter in the PUCCH structure settings.

Parameters:

<Format> <numeric value>
 <numeric value>
SUBF
 Selects the definition of N_PUCCH on subframe level.
 *RST: 0

Example:

CONF:UL:PUCCh:NPAR 2
 Sets N_PUCCH to 2.

Manual operation: See " [N_PUCCH](#)" on page 61

PRACH Structure

CONFigure[:LTE]:UL:PRACH:APM.....	157
CONFigure[:LTE]:UL:PRACH:CONF.....	157
CONFigure[:LTE]:UL:PRACH:FOFFset.....	157
CONFigure[:LTE]:UL:PRACH:FRIndex.....	157
CONFigure[:LTE]:UL:PRACH:HFIndicator.....	158
CONFigure[:LTE]:UL:PRACH:NCSC.....	158

CONFigure[:LTE]:UL:PRACH:RSEQ.....	158
CONFigure[:LTE]:UL:PRACH:RSET.....	158
CONFigure[:LTE]:UL:PRACH:SINdex.....	158

CONFigure[:LTE]:UL:PRACH:APM <State>

This command turns automatic preamble mapping for the PRACH on and off.

Parameters:

<State> ON | OFF

Example:

CONF:UL:PRACH:APM ON
Turns automatic preamble mapping on.

Manual operation: See "[PRACH Preamble Mapping](#)" on page 63

CONFigure[:LTE]:UL:PRACH:CONF <Configuration>

This command selects the PRACH preamble format.

Parameters:

<Configuration> <numeric value>

Example:

CONF:UL:PRACH:CONF 2
Selects PRACH configuration 2.

Manual operation: See "[PRACH Configuration](#)" on page 62

CONFigure[:LTE]:UL:PRACH:FOFFset <Offset>

This command defines the PRACH frequency offset.

The command is available for preamble formats 0 to 3.

Parameters:

<Offset> Resource block offset.

Example:

CONF:UL:PRACH:FOFF 5
Defines a frequency offset of 5 resource blocks.

Manual operation: See "[Frequency Offset](#)" on page 63

CONFigure[:LTE]:UL:PRACH:FRINdex <FRINdex>

This command selects the PRACH frequency index.

Parameters:

<FRINdex> <numeric value>

Example:

CONF:UL:PRACH:FRIN 10
Selects the frequency index 10.

Manual operation: See "[PRACH Preamble Mapping](#)" on page 63

CONFigure[LTE]:UL:PRACH:HFINDicator <HFINDicator>

This command defines the PRACH half frame indicator.

Parameters:

<HFINDicator> <numeric value>

Example:

CONF:UL:PRAC:HFIN 5
Selects half frame indicator 5.

Manual operation: See "[PRACH Preamble Mapping](#)" on page 63

CONFigure[LTE]:UL:PRACH:NCSC <Configuration>

This command defines the Ncs configuration for the PRACH.

Parameters:

<Configuration> <numeric value>

Example:

CONF:UL:PRAC:NCSC 1
Selects Ncs configuration 1.

Manual operation: See "[Ncs Conf](#)" on page 63

CONFigure[LTE]:UL:PRACH:RSEQ <RootSeqIdx>

This command defines the PRACH logical root sequence index.

Parameters:

<RootSeqIdx> <numeric value>

Example:

CONF:UL:PRAC:RSEQ 2
Selects logical root sequence index 2.

Manual operation: See "[Logical Root Sequ. Idx](#)" on page 63

CONFigure[LTE]:UL:PRACH:RSET <State>

This command turns the restricted preamble set for PRACH on and off.

Parameters:

<State> ON | OFF
*RST: OFF

Example:

CONF:UL:PRAC:RSET ON
Turns the restricted set on.

Manual operation: See "[Restricted Set](#)" on page 62

CONFigure[LTE]:UL:PRACH:SINDEX <Index>

This command selects the PRACH sequence index.

Parameters:
 <Index> <IndexValue>
 Number that defines the index manually.
AUTO
 Automatically determines the index.

Example: CONF:UL:PRAC:SIND 2
 Selects sequence index 2.

Manual operation: See "Sequence Index (v)" on page 63

7.10.2.2 Input / Frontend

Configuring the Input

Remote commands to configure the input described elsewhere:

- INPut:COUPling on page 164
- INPut:IMPedance on page 165
- [SENSe]:SWAPiq on page 168

INPut:FILTer:HPASs[:STATe].....	159
INPut:FILTer:YIG[:STATe].....	159
INPut:SElect.....	160

INPut:FILTer:HPASs[:STATe] <State>

Activates an additional internal high-pass filter for RF input signals from 1 GHz to 3 GHz. This filter is used to remove the harmonics of the R&S FPS in order to measure the harmonics for a DUT, for example.

This function requires an additional high-pass filter hardware option.

(Note: for RF input signals outside the specified range, the high-pass filter has no effect. For signals with a frequency of approximately 4 GHz upwards, the harmonics are suppressed sufficiently by the YIG filter.)

Parameters:
 <State> ON | OFF
 *RST: OFF

Example: INP:FILT:HPAS ON
 Turns on the filter.

Usage: SCPI confirmed

INPut:FILTer:YIG[:STATe] <State>

This command turns the YIG-preselector on and off.

Note the special conditions and restrictions for the YIG filter described in "YIG-Preselector" on page 64.

Parameters:

<State> ON | OFF | 0 | 1
 *RST: 1 (0 for I/Q Analyzer, GSM, VSA and MC Group Delay measurements)

Example:

INP:FILT:YIG OFF
 Deactivates the YIG-preselector.

Manual operation: See "YIG-Preselector" on page 64

INPut:SElect <Source>

This command selects the signal source for measurements, i.e. it defines which connector is used to input data to the R&S FPS. If no additional input options are installed, only RF input is supported.

Parameters:

<Source> RF
 Radio Frequency ("RF INPUT" connector)
 *RST: RF

Defining the Frequency

[SENSe]:FREQuency:CENTer[:CC<cci>].....	160
[SENSe]:FREQuency:CENTer[:CC<cci>]:OFFSet.....	161
[SENSe]:FREQuency:CENTer:STEP.....	161
[SENSe]:FREQuency:CENTer:STEP:LINK.....	162
[SENSe]:FREQuency:CENTer:STEP:LINK:FACTOR.....	162

[SENSe]:FREQuency:CENTer[:CC<cci>] <Frequency>

This command sets the center frequency for RF measurements.

Component carrier measurements

- Defining or querying the frequency of the first carrier is possible with `FREQ:CENT:CC1`. The `CC1` part of the syntax is mandatory in that case.
- `FREQ:CENT?` queries the measurement frequency (center of the two carriers).

Parameters:

<Frequency> <numeric value>
 Range: fmin to fmax
 *RST: 1 GHz
 Default unit: Hz

Example:

Measurement on one carrier:
`FREQ:CENT 1GHZ`
 Defines a center frequency of 1 GHz

Example:

Measurement on aggregated carriers:
`FREQ:CENT:CC1 850MHZ`
 Defines a center frequency of 850 MHz for the first carrier.

Manual operation: See ["Defining the Signal Frequency"](#) on page 64
See ["Remote commands to configure carrier aggregation"](#) on page 77

[SENSe]:FREQuency:CENTer[:CC<cci>]:OFFSet <Frequency>

This command defines the general frequency offset or the frequency offset for a component carrier.

The effect of the command depends on the syntax:

- When you omit the [CC<cci>] syntax element, the command defines the overall frequency offset.
In that case, the value is added to the measurement frequency and, in case of measurements with component carriers, the center frequency of the component carriers.
- When you include the [CC<cci>] syntax element, the command defines the offset of the component carrier relative the first component carrier.
In that case, the command is not available for the first component carrier - thus, ...:CC1:... is not possible.

Parameters:

<Frequency>

- General frequency offset: frequency offset in Hz.
- Component carrier offset: frequency offset relative to the first component carrier in Hz.

Example:

```
FREQ:CENT:OFFS 50HZ
```

Adds a frequency offset of 50 Hz to the measurement frequency. If you are measuring component carriers, the value is also added to the center frequencies of those carriers.

```
FREQ:CENT:CC2:OFFS 15MHZ
```

Defines a frequency offset of 15 MHz for the second component carrier relative to the first component carrier.

Manual operation: See ["Defining the Signal Frequency"](#) on page 64
See ["Remote commands to configure carrier aggregation"](#) on page 77

[SENSe]:FREQuency:CENTer:STEP <StepSize>

This command defines the center frequency step size.

You can increase or decrease the center frequency quickly in fixed steps using the SENS:FREQ UP and SENS:FREQ DOWN commands, see [\[SENSe\]:FREQuency:CENTer\[:CC<cci>\]](#) on page 160.

Parameters:

<StepSize>

f_{\max} is specified in the data sheet.

Range: 1 to fMAX

*RST: 0.1 x span

Default unit: Hz

Example: FREQ:CENT 100 MHz
 FREQ:CENT:STEP 10 MHz
 FREQ:CENT UP
 Sets the center frequency to 110 MHz.

Manual operation: See "Defining the Signal Frequency" on page 64

[SENSe:]FREQuency:CENTer:STEP:LINK <CouplingType>

This command couples and decouples the center frequency step size to the span or the resolution bandwidth.

Parameters:

<CouplingType> **SPAN**
 Couples the step size to the span. Available for measurements in the frequency domain.

OFF
 Decouples the step size.

*RST: SPAN

Example: FREQ:CENT:STEP:LINK SPAN

[SENSe:]FREQuency:CENTer:STEP:LINK:FACTor <Factor>

Parameters:

<Factor> 1 to 100 PCT
 *RST: 10

Example: FREQ:CENT:STEP:LINK:FACT 20PCT

Configuring the Vertical Axis

CALCulate<n>:UNIT:POWer.....	162
DISPlay[:WINDow<n>]:TRACe<t>:Y[:SCALE]:RLEVel.....	163
DISPlay[:WINDow<n>]:TRACe<t>:Y[:SCALE]:RLEVel:OFFSet.....	163
INPut:ATTenuation.....	163
INPut:ATTenuation:AUTO.....	164
INPut:COUPling.....	164
INPut:GAIN:STATe.....	164
INPut:IMPedance.....	165
INPut<n>:EATT.....	165
INPut<n>:EATT:AUTO.....	165
INPut<n>:EATT:STATe.....	166
[SENSe:]ADJust:LEVel.....	166

CALCulate<n>:UNIT:POWer <Unit>

This command selects the unit of the y-axis.

The unit applies to all measurement windows.

Parameters:

<Unit> DBM | V | A | W | DBPW | WATT | DBUV | DBMV | VOLT |
 DBUA | AMPere
 *RST: dBm

Example:

CALC:UNIT:POW DBM
 Sets the power unit to dBm.

Manual operation: See ["Defining a Reference Level"](#) on page 65

DISPlay[:WINDow<n>]:TRACe<t>:Y[:SCALe]:RLEVel <ReferenceLevel>

This command defines the reference level (for all traces, <t> is irrelevant).

With a reference level offset ≠ 0, the value range of the reference level is modified by the offset.

Parameters:

<ReferenceLevel> The unit is variable.
 Range: see datasheet
 *RST: 0 dBm

Example:

DISP:TRAC:Y:RLEV -60dBm

Usage:

SCPI confirmed

Manual operation: See ["Defining a Reference Level"](#) on page 65

DISPlay[:WINDow<n>]:TRACe<t>:Y[:SCALe]:RLEVel:OFFSet <Offset>

This command defines a reference level offset (for all traces, <t> is irrelevant).

Parameters:

<Offset> Range: -200 dB to 200 dB
 *RST: 0dB

Example:

DISP:TRAC:Y:RLEV:OFFS -10dB

Manual operation: See ["Defining a Reference Level"](#) on page 65

INPut:ATTenuation <Attenuation>

This command defines the total attenuation for RF input.

If you set the attenuation manually, it is no longer coupled to the reference level, but the reference level is coupled to the attenuation. Thus, if the current reference level is not compatible with an attenuation that has been set manually, the command also adjusts the reference level.

Parameters:

<Attenuation> Range: see data sheet
 Increment: 5 dB
 *RST: 10 dB (AUTO is set to ON)

- Example:** `INP:ATT 30dB`
Defines a 30 dB attenuation and decouples the attenuation from the reference level.
- Usage:** SCPI confirmed
- Manual operation:** See "[Attenuating the Signal](#)" on page 66

INPut:ATTenuation:AUTO <State>

This command couples or decouples the attenuation to the reference level. Thus, when the reference level is changed, the R&S FPS determines the signal level for optimal internal data processing and sets the required attenuation accordingly.

Parameters:

<State> ON | OFF | 0 | 1
*RST: 1

- Example:** `INP:ATT:AUTO ON`
Couples the attenuation to the reference level.

- Usage:** SCPI confirmed
- Manual operation:** See "[Attenuating the Signal](#)" on page 66

INPut:COUPling <CouplingType>

This command selects the coupling type of the RF input.

Parameters:

<CouplingType> **AC**
AC coupling
DC
DC coupling
*RST: AC

- Example:** `INP:COUP DC`
- Usage:** SCPI confirmed
- Manual operation:** See "[Input Coupling](#)" on page 67

INPut:GAIN:STATe <State>

This command turns the preamplifier on and off.

If activated, the input signal is amplified by 20 dB.

If option R&S FPS-B22 is installed, the preamplifier is only active below 7 GHz.

If option R&S FPS-B24 is installed, the preamplifier is active for all frequencies.

Parameters:

<State> ON | OFF
 *RST: OFF

Example:

INP:GAIN:STAT ON
 Switches on 20 dB preamplification.

Usage:

SCPI confirmed

Manual operation: See "[Preamplifier \(option B22/B24\)](#)" on page 67

INPut:IMPedance <Impedance>

This command selects the nominal input impedance of the RF input.

75 Ω should be selected if the 50 Ω input impedance is transformed to a higher impedance using a matching pad of the RAZ type (= 25 Ω in series to the input impedance of the instrument). The power loss correction value in this case is 1.76 dB = 10 log (75 Ω /50 Ω).

Parameters:

<Impedance> 50 | 75
 *RST: 50 Ω

Example:

INP:IMP 75

Usage:

SCPI confirmed

Manual operation: See "[Impedance](#)" on page 67

INPut<n>:EATT <Attenuation>

This command defines the electronic attenuation level.

If the current reference level is not compatible with an attenuation that has been set manually, the command also adjusts the reference level.

This command requires the optional Electronic Attenuator.

Parameters:

<Attenuation> Attenuation level in dB.
 Default unit: dB

Example:

INP:EATT 10
 Defines an attenuation level of 10 dB.

Manual operation: See "[Attenuating the Signal](#)" on page 66

INPut<n>:EATT:AUTO <State>

This command turns automatic selection of the electronic attenuation on and off.

If on, electronic attenuation reduces the mechanical attenuation whenever possible.

This command requires the optional Electronic Attenuator.

Parameters:

<State> ON | OFF
 *RST: OFF

Example:

INP:EATT:AUTO ON
 Turns automatic selection of electronic attenuation level on.

Manual operation: See ["Attenuating the Signal"](#) on page 66

INPut<n>:EATT:STATe <State>

This command turns the electronic attenuator on and off.

This command requires the optional Electronic Attenuator.

Parameters:

<State> ON | OFF
 *RST: OFF

Example:

INP:EATT:STAT ON
 Turns the electronic attenuator on.

Manual operation: See ["Attenuating the Signal"](#) on page 66

[SENSe:]ADJust:LEVel

This command initiates a single (internal) measurement that evaluates and sets the ideal reference level for the current input data and measurement settings. This ensures that the settings of the RF attenuation and the reference level are optimally adjusted to the signal level without overloading the R&S FPS or limiting the dynamic range by an S/N ratio that is too small.

Example: ADJ:LEV

Usage: Event

Manual operation: See ["Defining a Reference Level"](#) on page 65

7.10.2.3 Signal Capture

- [Data Capture](#)..... 166
- [Trigger](#)..... 168

Data Capture

[SENSe][:LTE]:FRAMe:COUNT	167
[SENSe][:LTE]:FRAMe:COUNT:AUTO	167
[SENSe][:LTE]:FRAMe:COUNT:STATe	167
[SENSe][:LTE]:FRAMe:SSUBframe	168
[SENSe]:SWAPiq	168
[SENSe]:SWEp:TIME	168

[SENSe][:LTE]:FRAMe:COUNT <Subframes>

This command sets the number of frames you want to analyze.

Parameters:

<Subframes> <numeric value>
*RST: 1

Example:

```
FRAM:COUN:STAT ON
FRAM:COUN:AUTO OFF
Activates manual input of frames to be analyzed.
FRAM:COUN 20
Analyzes 20 frames.
```

Manual operation: See ["Number of Frames to Analyze"](#) on page 69

[SENSe][:LTE]:FRAMe:COUNT:AUTO <State>

This command turns automatic selection of the number of frames to analyze on and off.

Parameters:

<State> **ON**
Selects the number of frames to analyze according to the LTE standard.

OFF

Turns manual selection of the frame number on.

Example:

```
FRAM:COUN:AUTO ON
Turns automatic selection of the analyzed frames on.
```

Manual operation: See ["Auto According to Standard"](#) on page 69

[SENSe][:LTE]:FRAMe:COUNT:STATe <State>

This command turns manual selection of the number of frames you want to analyze on and off.

Parameters:

<State> **ON**
You can set the number of frames to analyze.

OFF

The R&S FPS analyzes a single sweep.

*RST: ON

Example:

```
FRAM:COUN:STAT ON
Turns manual setting of number of frames to analyze on.
```

Manual operation: See ["Overall Frame Count"](#) on page 68

[SENSe:] [LTE:] FRAMe:SSUBframe <State>

This command turns the analysis of a single subframe only on and off.

Parameters:

<State> ON | OFF
*RST: OFF

Example:

FRAM:SSUB ON
Evaluates a single subframe only.

Manual operation: See ["Single Subframe Mode"](#) on page 69

[SENSe]:SWAPiq <State>

This command turns a swap of the I and Q branches on and off.

Parameters:

<State> ON | OFF
*RST: OFF

Example:

SWAP ON
Turns a swap of the I and Q branches on.

Manual operation: See ["Swap I/Q"](#) on page 68

[SENSe]:SWEep:TIME <CaptLength>

This command sets the capture time.

Parameters:

<CaptLength> Numeric value in seconds.
Default unit: s

Example:

SWE:TIME 40ms
Defines a capture time of 40 milliseconds.

Manual operation: See ["Capture Time"](#) on page 68

Trigger

The trigger functionality of the LTE measurement application is the same as that of the R&S FPS.

For a comprehensive description of the available remote control commands for trigger configuration see the documentation of the R&S FPS.

TRIGger[:SEQuence]:HOLDoff<instrument>	169
TRIGger[:SEQuence]:LEVel<instrument>[:EXTernal]	169
TRIGger[:SEQuence]:PORT<instrument>	169
TRIGger[:SEQuence]:SLOPe	169
TRIGger[:SEQuence]:SOURce	170

TRIGger[:SEQuence]:HOLDoff<instrument> <Offset>

This command defines the trigger offset.

Parameters:

<Offset> <numeric value>
*RST: 0 s
Default unit: s

Example: TRIG:HOLD 5MS
Sets the trigger offset to 5 ms.

TRIGger[:SEQuence]:LEVel<instrument>[:EXTernal] <Level>

This command defines the level for an external trigger.

Parameters:

<Level> Range: 0.5 V to 3.5 V
*RST: 1.4 V
Default unit: V

Example: TRIG:LEV 2V
Defines a trigger level of 2 V.

TRIGger[:SEQuence]:PORT<instrument> <Port>

This command selects the trigger port for measurements with devices that have several trigger ports.

Parameters:

<Port> **PORT1**
 PORT2
 PORT3

Example: TRIG:PORT PORT1
Selects trigger port 1.

TRIGger[:SEQuence]:SLOPe <Type>

For external and time domain trigger sources you can define whether triggering occurs when the signal rises to the trigger level or falls down to it.

Parameters:

<Type> POSitive | NEGative
POSitive
Triggers when the signal rises to the trigger level (rising edge).
NEGative
Triggers when the signal drops to the trigger level (falling edge).
*RST: POSitive

Example: TRIG:SLOP NEG

TRIGger[:SEQuence]:SOURce <Source>

This command selects the trigger source.

Note on external triggers:

If a measurement is configured to wait for an external trigger signal in a remote control program, remote control is blocked until the trigger is received and the program can continue. Make sure this situation is avoided in your remote control programs.

Parameters:

- <Source> **IMMediate**
Free Run
- EXTernal**
Trigger signal from the TRIGGER IN connector.
- EXT2**
Trigger signal from the TRIGGER AUX connector.
- RFPower**
First intermediate frequency
- IFPower**
Second intermediate frequency
- IQPower**
Magnitude of sampled I/Q data
For applications that process I/Q data, such as the I/Q Analyzer or optional applications.
- *RST: IMMediate

Example: TRIG:SOUR EXT
Selects the external trigger input as source of the trigger signal

7.10.2.4 Demodulation

[SENSe][:LTE]:UL:DEMod:ATTSlots.....	170
[SENSe][:LTE]:UL:DEMod:MODE.....	171
[SENSe][:LTE]:UL:DEMod:CESTimation.....	171
[SENSe][:LTE]:UL:DEMod:EEPeriod.....	171
[SENSe][:LTE]:UL:DEMod:CDOffset.....	171
[SENSe][:LTE]:UL:DEMod:CBSCrambling.....	172
[SENSe][:LTE]:UL:DEMod:SISync.....	172
[SENSe][:LTE]:UL:DEMod:MCFilter.....	172

[SENSe][:LTE]:UL:DEMod:ATTSlots <State>

This command includes or excludes the transient slots present after a switch from downlink to uplink in the analysis.

Parameters:

- <State> ON | OFF

Example: UL:DEM:ATTS ON
Includes the transient slots in the analysis.

Manual operation: See ["Analyze TDD Transient Slots"](#) on page 72

[SENSe][:LTE]:UL:DEMod:MODE <Reference>

This command selects the uplink analysis mode.

Parameters:

<Reference>

PUSCh

Analyzes the PUSCH and PUCCH.

PRACH

Analyzes the PRACH.

*RST: PUSCh

Example:

UL:DEMod:MODE PRACH

Selects PRACH analysis mode.

Manual operation: See ["Analysis Mode"](#) on page 71

[SENSe][:LTE]:UL:DEMod:CESTimation <Type>

This command selects the channel estimation type for uplink signals.

Parameters:

<Type>

PIL | PILPAY

PIL

Pilot only

PILP

Pilot and payload

*RST: PILP

Example:

UL:DEMod:CEST PIL

Uses only the pilot signal for channel estimation.

Manual operation: See ["Channel Estimation Range"](#) on page 71

[SENSe][:LTE]:UL:DEMod:EEPeriod <State>

This command includes or excludes the exclusion period from EVM results.

Parameters:

<State>

ON | OFF

Example:

UL:DEMod:EEP ON

Turns the exclusion periods for EVM calculation on.

Manual operation: See ["EVM with Exclusion Period"](#) on page 72

[SENSe][:LTE]:UL:DEMod:CDOffset <State>

This command turns DC offset compensation for uplink signals on and off.

Parameters:

<State> ON | OFF
 *RST: ON

Example:

UL:DEM:CDC OFF
 Deactivates DC offset compensation.

Manual operation: See "[Compensate DC Offset](#)" on page 72

[SENSe][:LTE]:UL:DEMod:CBSCrambling <State>

This command turns scrambling of coded bits for uplink signals on and off.

Parameters:

<State> ON | OFF
 *RST: ON

Example:

UL:DEM:CBSC OFF
 Deactivates the scrambling.

Manual operation: See "[Scrambling of Coded Bits](#)" on page 72

[SENSe][:LTE]:UL:DEMod:SISync <State>

This command turns suppressed interference synchronization on and off.

Parameters:

<State> ON | OFF
 *RST: OFF

Example:

UL:DEM:SISY ON
 Turns suppressed interference synchronization on.

Manual operation: See "[Suppressed Interference Synchronization](#)" on page 73

[SENSe][:LTE]:UL:DEMod:MCFilter <State>

This command turns suppression of interfering neighboring carriers on and off (e.g. LTE, WCDMA, GSM etc).

Parameters:

<State> ON | OFF
 *RST: OFF

Example:

UL:DEM:MCF ON
 Turns suppression on of neighboring carriers on.

Manual operation: See "[Multicarrier Filter](#)" on page 73

7.10.2.5 Tracking

[SENSe][:LTE]:UL:TRACking:PHASe..... 173
 [SENSe][:LTE]:UL:TRACking:TIME..... 173

[SENSe][:LTE]:UL:TRACking:PHASe <Type>

This command selects the phase tracking type for uplink signals.

Parameters:

- <Type> **OFF**
Deactivate phase tracking
- PIL**
Pilot only
- PILP**
Pilot and payload
- *RST: OFF

Example: SENS:UL:TRAC:PHAS PILP
Use pilots and payload for channel estimation.

Manual operation: See "Phase" on page 70

[SENSe][:LTE]:UL:TRACking:TIME <State>

This command turns timing tracking for uplink signals on and off.

Parameters:

- <State> ON | OFF
- *RST: OFF

Example: UL:TRAC:TIME ON
Activates timing tracking.

Manual operation: See "Timing" on page 71

7.10.3 Configuring Frequency Sweep Measurements

Please refer to the documentation of the R&S FPS base unit for a comprehensive list and description of remote commands necessary to configure and perform frequency sweep measurements (ACLR and SEM).

All commands specific to the LTE application are listed below.

CONFigure[:LTE]:UL:CABW..... 174
 CONFigure:NOCC..... 174
 [SENSe]:POWer:ACHannel:AACHannel..... 175
 [SENSe]:POWer:SEM:UL:REQUIREment..... 175

CONFigure[:LTE]:UL:CABW <Bandwidth>

This command selects the channel bandwidth(s) of the carriers in MC ACLR measurements.

Parameters:

<Bandwidth>

B520

First carrier: 5 MHz, second carrier: 20 MHz bandwidth.

B1020

First carrier: 10 MHz, second carrier: 20 MHz bandwidth.

B1515

First carrier: 15 MHz, second carrier: 15 MHz bandwidth.

B1520

First carrier: 15 MHz, second carrier: 20 MHz bandwidth.

B2020

First carrier: 20 MHz, second carrier: 20 MHz bandwidth.

USER

Custom combination of bandwidths. Define the bandwidths of both carriers with `CONFigure[:LTE]:UL[:CC<cci>]:BW` on page 138.

Example:

```
CONF:UL:CABW USER
```

```
CONF:UL:CC1:BW BW5_00
```

```
CONF:UL:CC2:BW BW5_00
```

Custom bandwidth combination: first carrier 5 MHz, second carrier 5 MHz.

Manual operation: See "[Remote commands to configure carrier aggregation](#)" on page 77

CONFigure:NOCC <Carriers>

This command selects the number of component carriers evaluated in the Time Alignment measurement.

Parameters:

<Carriers>

Number of the component carriers that you would like to measure. The range depends on the measurement.

For more information see "[Carrier Aggregation](#)" on page 76.

```
*RST: 1
```

Example:

```
CONF:NOCC 2
```

Selects 2 carriers.

Manual operation: See "[Remote commands to configure carrier aggregation](#)" on page 77

[SENSe]:POWer:ACHannel:AACHannel <Bandwidth>

This command selects the bandwidth of the adjacent channel for ACLR measurements.

Parameters:

<Channel>

EUTRA

Selects an EUTRA signal of the same bandwidth like the TX channel as assumed adjacent channel carrier.

UTRA128

Selects an UTRA signal with a bandwidth of 1.28MHz as assumed adjacent channel carrier.

UTRA384

Selects an UTRA signal with a bandwidth of 3.84MHz as assumed adjacent channel carrier.

UTRA768

Selects an UTRA signal with a bandwidth of 7.68MHz as assumed adjacent channel carrier.

*RST: EUTRA

Example:

POW:ACH:AACH UTRA384

Selects an UTRA signal with a bandwidth of 3.84MHz as assumed adjacent channel carrier.

Manual operation: See "[Assumed Adjacent Channel Carrier](#)" on page 74

[SENSe]:POWer:SEM:UL:REQUIREment <Requirement>

This command selects the requirements for a spectrum emission mask.

Parameters:

<Requirement>

GEN | NS3 | NS4 | NS67

GEN

General spectrum emission mask.

NS3 | NS4 | NS67

Spectrum emission masks with additional requirements.

Example:

POW:SEM:UL:REQ NS3

Selects a spectrum emission mask with requirement for network signalled value NS3.

Manual operation: See "[SEM Requirement](#)" on page 75

7.11 Analysis

- [Evaluation Range](#)..... 176
- [Y-Axis Scale](#)..... 179
- [Result Settings](#)..... 180

7.11.1 Evaluation Range

[SENSe][:LTE]:ALlocation:SElect.....	176
[SENSe][:LTE]:CARRier:SElect.....	176
[SENSe][:LTE]:MODulation:SElect.....	177
[SENSe][:LTE]:PREamble:SElect.....	177
[SENSe][:LTE]:SLOT:SElect.....	177
[SENSe][:LTE]:SUBFrame:SElect.....	178
[SENSe][:LTE]:SYMBOL:SElect.....	178

[SENSe][:LTE]:ALlocation:SElect <Allocation>

This command filters the displayed results in the constellation diagram by a particular type of allocation.

Parameters:

<Allocation>

ALL

Shows the results for all allocations.

<numeric_value>

Shows the results for a particular allocation type.

Allocation types are mapped to numeric values. For the code assignment see [chapter 7.7.1.20, "Return Value Codes"](#), on page 114.

*RST: ALL

Example:

ALL:SEL 2

Shows the results for PDSCH allocation 2.

Manual operation:

See ["Evaluation Range for the Constellation Diagram"](#) on page 80

[SENSe][:LTE]:CARRier:SElect <Carrier>

This command filters the displayed results in the constellation diagram by a particular subcarrier.

Parameters:

<Carrier>

ALL

Shows the results for all subcarriers.

<numeric_value>

Shows the results for a particular subcarrier.

*RST: ALL

Example:

CARR:SEL 1

Shows the results for subcarrier 1.

Manual operation:

See ["Evaluation Range for the Constellation Diagram"](#) on page 80

[SENSe][:LTE]:MODulation:SElect <Modulation>

This command filters the displayed results in the constellation diagram by a particular type of modulation.

Parameters:

<Modulation>

ALL

Shows the results for all modulation types.

<numeric_value>

Shows the results for a particular modulation type.

Modulation types are mapped to numeric values. For the code assignment see [chapter 7.7.1.20, "Return Value Codes"](#), on page 114.***RST:** ALL**Example:**

MOD:SEL 3

Shows the results for all elements with a 16QAM modulation

Manual operation: See ["Evaluation Range for the Constellation Diagram"](#) on page 80

[SENSe][:LTE]:PREamble:SElect <Subframe>

This command selects a particular preamble for measurements that analyze individual preambles.

The command is available in PRACH analysis mode.

Parameters:

<Subframe>

ALL

Analyzes all preambles.

<numeric value>

Selects the preamble to analyze.

***RST:** ALL**Example:**

PRE:SEL ALL

Analyzes all preambles.

Manual operation: See ["Preamble Selection"](#) on page 80

[SENSe][:LTE]:SLOT:SElect <Slot>

This command selects the slot to analyze.

Parameters:

<Slot> **S0**
Slot 0

S1
Slot 1

ALL
Both slots

*RST: ALL

Example:

SLOT:SEL S1
Selects slot 1 for analysis.

Manual operation: See "[Slot Selection](#)" on page 80

[SENSe][:LTE]:SUBFrame:SElect <Subframe>

This command selects the subframe to be analyzed.

Parameters:

<Subframe> ALL | <numeric value>

ALL
Select all subframes

0...39
Select a single subframe

*RST: ALL

Example:

SUBF:SEL ALL
Select all subframes for analysis.

Manual operation: See "[Subframe Selection](#)" on page 79

[SENSe][:LTE]:SYMBOL:SElect <Symbol>

This command filters the displayed results in the constellation diagram by a particular OFDM symbol.

Parameters:

<Symbol> **ALL**
Shows the results for all subcarriers.

 <numeric_value>
Shows the results for a particular OFDM symbol.

*RST: ALL

Example:

SYMB:SEL 2
Shows the results for the second OFDM symbol.

Manual operation: See "[Evaluation Range for the Constellation Diagram](#)" on page 80

7.11.2 Y-Axis Scale

DISPlay[:WINDow<n>]:TRACe<t>:Y[:SCALe]:AUTO ONCE.....	179
DISPlay[:WINDow<n>]:TRACe<t>:Y[:SCALe]:MAXimum.....	179
DISPlay[:WINDow<n>]:TRACe<t>:Y[:SCALe]:MINimum.....	179

DISPlay[:WINDow<n>]:TRACe<t>:Y[:SCALe]:AUTO ONCE

Automatic scaling of the y-axis is performed once, then switched off again (for all traces, <t> is irrelevant).

Usage: SCPI confirmed

Manual operation: See "Y-Axis Scale" on page 81

DISPlay[:WINDow<n>]:TRACe<t>:Y[:SCALe]:MAXimum <Value>

This command defines the maximum value of the y-axis for all traces in the selected result display.

The suffix <t> is irrelevant.

Parameters:

<Value> <numeric value>
 *RST: depends on the result display
 The unit and range depend on the result display.

Example: DISP:TRAC:Y:MIN -60
 DISP:TRAC:Y:MAX 0
 Defines the y-axis with a minimum value of -60 and maximum value of 0.

Manual operation: See "Y-Axis Scale" on page 81

DISPlay[:WINDow<n>]:TRACe<t>:Y[:SCALe]:MINimum <Value>

This command defines the minimum value of the y-axis for all traces in the selected result display.

The suffix <t> is irrelevant.

Parameters:

<Value> <numeric value>
 *RST: depends on the result display
 The unit and range depend on the result display.

Example: DISP:TRAC:Y:MIN -60
 DISP:TRAC:Y:MAX 0
 Defines the y-axis with a minimum value of -60 and maximum value of 0.

Manual operation: See "Y-Axis Scale" on page 81

7.11.3 Result Settings

CALCulate:MARKer:COUPling.....	180
UNIT:BSTR.....	180
UNIT:CAXes.....	180
UNIT:EVM.....	181

CALCulate:MARKer:COUPling <State>

This command couples or decouples markers in different result displays to each other.

Parameters:

<State> ON | OFF

Example:

CALC:MARK:COUP ON
Couples the markers to each other.

Manual operation: See "[Marker Coupling](#)" on page 83

UNIT:BSTR <Unit>

This command selects the way the bit stream is displayed.

Parameters:

<Unit> **SYMBOLS**
Displays the bit stream using symbols

BITS
Displays the bit stream using bits

*RST: SYMBOLS

Example:

UNIT:BSTR BIT
Bit stream gets displayed using Bits.

Manual operation: See "[Bit Stream Format](#)" on page 82

UNIT:CAXes <Unit>

This command selects the scale of the x-axis for result displays that show subcarrier results.

Parameters:

<Unit> **CARR**
Shows the number of the subcarriers on the x-axis.

HZ
Shows the frequency of the subcarriers on the x-axis.

Example:

UNIT:CAX HZ
Selects frequency scale for the x-axis.

Manual operation: See "[Carrier Axes](#)" on page 82

UNIT:EVM <Unit>

This command selects the EVM unit.

Parameters:

<Unit>

DB
EVM results returned in dB
PCT
EVM results returned in %
*RST: PCT

Example: UNIT:EVM PCT
EVM results to be returned in %.

Manual operation: See "[EVM Unit](#)" on page 82

List of Commands

[SENSe:]LTE:]FRAMe:SSUBframe.....	168
[SENSe:]ADJust:LEVel.....	166
[SENSe:]FREQUency:CENTer:STEP.....	161
[SENSe:]FREQUency:CENTer:STEP:LINK.....	162
[SENSe:]FREQUency:CENTer:STEP:LINK:FACTor.....	162
[SENSe:]FREQUency:CENTer[:CC<cci>].....	160
[SENSe:]FREQUency:CENTer[:CC<cci>]:OFFSet.....	161
[SENSe:]POWer:ACHannel:AACHannel.....	175
[SENSe:]POWer:SEM:UL:REQUIREment.....	175
[SENSe:]SWAPiq.....	168
[SENSe:]SWEep:TIME.....	168
[SENSe:]SYNC[:STATe]?	103
[SENSe][:LTE]:ALLocation:SElect.....	176
[SENSe][:LTE]:CARRier:SElect.....	176
[SENSe][:LTE]:FRAMe:COUNT.....	167
[SENSe][:LTE]:FRAMe:COUNT:AUTO.....	167
[SENSe][:LTE]:FRAMe:COUNT:STATe.....	167
[SENSe][:LTE]:MODulation:SElect.....	177
[SENSe][:LTE]:OOPower:ATIMing.....	103
[SENSe][:LTE]:PREamble:SElect.....	177
[SENSe][:LTE]:SFLatness:ECONditions.....	142
[SENSe][:LTE]:SFLatness:OBANd.....	142
[SENSe][:LTE]:SLOT:SElect.....	177
[SENSe][:LTE]:SUBFrame:SElect.....	178
[SENSe][:LTE]:SYMBOL:SElect.....	178
[SENSe][:LTE]:UL:DEMod:ACON.....	147
[SENSe][:LTE]:UL:DEMod:ATTSlots.....	170
[SENSe][:LTE]:UL:DEMod:CBSCrambling.....	172
[SENSe][:LTE]:UL:DEMod:CDCOffset.....	171
[SENSe][:LTE]:UL:DEMod:CESTimation.....	171
[SENSe][:LTE]:UL:DEMod:EEPeriod.....	171
[SENSe][:LTE]:UL:DEMod:MCFilter.....	172
[SENSe][:LTE]:UL:DEMod:MODE.....	171
[SENSe][:LTE]:UL:DEMod:SISYnc.....	172
[SENSe][:LTE]:UL:FORMat:SCD.....	147
[SENSe][:LTE]:UL:TRACking:PHASe.....	173
[SENSe][:LTE]:UL:TRACking:TIME.....	173
ABORT.....	101
CALCulate:MARKer:COUPling.....	180
CALCulate<n>:DELTAmarker<m>:X.....	126
CALCulate<n>:DELTAmarker<m>:Y?	126
CALCulate<n>:LIMit<k>:ACPower:ACHannel:RESult?	127
CALCulate<n>:LIMit<k>:ACPower:ALTErnate:RESult?	128
CALCulate<n>:LIMit<k>:FAIL?	128
CALCulate<n>:LIMit<k>:SUMMary:EVM:PCHannel:MAXimum:RESult.....	130
CALCulate<n>:LIMit<k>:SUMMary:EVM:PCHannel[:AVERAge]:RESult?	130
CALCulate<n>:LIMit<k>:SUMMary:EVM:PSIGnal:MAXimum:RESult.....	130

CALCulate<n>:LIMit<k>:SUMMary:EVM:PSIGnal[:AVERAge]:RESult?.....	130
CALCulate<n>:LIMit<k>:SUMMary:EVM:SDQP[:AVERAge]:RESult?.....	130
CALCulate<n>:LIMit<k>:SUMMary:EVM:SDSF[:AVERAge]:RESult?.....	131
CALCulate<n>:LIMit<k>:SUMMary:EVM:SDST[:AVERAge]:RESult?.....	131
CALCulate<n>:LIMit<k>:SUMMary:EVM:UCCD[:AVERAge]:RESult?.....	132
CALCulate<n>:LIMit<k>:SUMMary:EVM:UCCH[:AVERAge]:RESult?.....	132
CALCulate<n>:LIMit<k>:SUMMary:EVM:UPRA[:AVERAge]:RESult?.....	132
CALCulate<n>:LIMit<k>:SUMMary:EVM:USQP[:AVERAge]:RESult?.....	133
CALCulate<n>:LIMit<k>:SUMMary:EVM:USSF[:AVERAge]:RESult?.....	133
CALCulate<n>:LIMit<k>:SUMMary:EVM:USST[:AVERAge]:RESult?.....	133
CALCulate<n>:LIMit<k>:SUMMary:EVM[:ALL]:MAXimum:RESult.....	129
CALCulate<n>:LIMit<k>:SUMMary:EVM[:ALL]:AVERAge:RESult?.....	129
CALCulate<n>:LIMit<k>:SUMMary:FERRor:MAXimum:RESult.....	134
CALCulate<n>:LIMit<k>:SUMMary:FERRor[:AVERAge]:RESult?.....	134
CALCulate<n>:LIMit<k>:SUMMary:GIMBalance:MAXimum:RESult.....	134
CALCulate<n>:LIMit<k>:SUMMary:GIMBalance[:AVERAge]:RESult?.....	134
CALCulate<n>:LIMit<k>:SUMMary:IQOFfset:MAXimum:RESult.....	134
CALCulate<n>:LIMit<k>:SUMMary:IQOFfset[:AVERAge]:RESult?.....	134
CALCulate<n>:LIMit<k>:SUMMary:QUADerror:MAXimum:RESult.....	135
CALCulate<n>:LIMit<k>:SUMMary:QUADerror[:AVERAge]:RESult?.....	135
CALCulate<n>:LIMit<k>:SUMMary:SERRor:MAXimum:RESult.....	135
CALCulate<n>:LIMit<k>:SUMMary:SERRor[:AVERAge]:RESult?.....	135
CALCulate<n>:MARKer<m>:FUNctioN:POWer:RESult[:CURRent]?.....	116
CALCulate<n>:MARKer<m>:X.....	126
CALCulate<n>:MARKer<m>:Y?.....	127
CALCulate<n>:UNIT:POWer.....	162
CONFigure:NOCC.....	174
CONFigure[:LTE]:DUPLexing.....	138
CONFigure[:LTE]:LDIRectioN.....	138
CONFigure[:LTE]:MEASurement.....	136
CONFigure[:LTE]:UL:CABW.....	174
CONFigure[:LTE]:UL:CSUBframes.....	143
CONFigure[:LTE]:UL:MIMO:ASElectioN.....	142
CONFigure[:LTE]:UL:PRACH:APM.....	157
CONFigure[:LTE]:UL:PRACH:CONF.....	157
CONFigure[:LTE]:UL:PRACH:FOFFset.....	157
CONFigure[:LTE]:UL:PRACH:FRINdex.....	157
CONFigure[:LTE]:UL:PRACH:HFINDicator.....	158
CONFigure[:LTE]:UL:PRACH:NCSC.....	158
CONFigure[:LTE]:UL:PRACH:RSEQ.....	158
CONFigure[:LTE]:UL:PRACH:RSET.....	158
CONFigure[:LTE]:UL:PRACH:SINdex.....	158
CONFigure[:LTE]:UL:PUCCh:DESHift.....	154
CONFigure[:LTE]:UL:PUCCh:FORMat.....	155
CONFigure[:LTE]:UL:PUCCh:N1CS.....	155
CONFigure[:LTE]:UL:PUCCh:N2RB.....	155
CONFigure[:LTE]:UL:PUCCh:NORB.....	156
CONFigure[:LTE]:UL:PUCCh:NPAR.....	156
CONFigure[:LTE]:UL:SFNO.....	147
CONFigure[:LTE]:UL:SRS:ANST.....	150

CONFigure[LTE]:UL:SRS:BHOP.....	150
CONFigure[LTE]:UL:SRS:BSRS.....	151
CONFigure[LTE]:UL:SRS:CSRS.....	151
CONFigure[LTE]:UL:SRS:CYCS.....	151
CONFigure[LTE]:UL:SRS:ISRS.....	151
CONFigure[LTE]:UL:SRS:MUPT.....	152
CONFigure[LTE]:UL:SRS:NRRC.....	152
CONFigure[LTE]:UL:SRS:POWer.....	152
CONFigure[LTE]:UL:SRS:STAT.....	152
CONFigure[LTE]:UL:SRS:SUConfig.....	153
CONFigure[LTE]:UL:SRS:TRComb.....	153
CONFigure[LTE]:UL:UEID.....	148
CONFigure[LTE]:UL[:CC<cci>]:BW.....	138
CONFigure[LTE]:UL[:CC<cci>]:CYCPrefix.....	139
CONFigure[LTE]:UL[:CC<cci>]:DRS:AOCc.....	148
CONFigure[LTE]:UL[:CC<cci>]:DRS:DSSHift.....	148
CONFigure[LTE]:UL[:CC<cci>]:DRS:GRPHopping.....	149
CONFigure[LTE]:UL[:CC<cci>]:DRS:NDMRs.....	149
CONFigure[LTE]:UL[:CC<cci>]:DRS:PUCCh:POWer.....	149
CONFigure[LTE]:UL[:CC<cci>]:DRS:SEQHopping.....	149
CONFigure[LTE]:UL[:CC<cci>]:DRS[:PUSCh]:POWer.....	149
CONFigure[LTE]:UL[:CC<cci>]:PLC:CID.....	139
CONFigure[LTE]:UL[:CC<cci>]:PLC:CIDGroup.....	140
CONFigure[LTE]:UL[:CC<cci>]:PLC:PLID.....	140
CONFigure[LTE]:UL[:CC<cci>]:PUSCh:FHMode.....	153
CONFigure[LTE]:UL[:CC<cci>]:PUSCh:FHOFFset.....	154
CONFigure[LTE]:UL[:CC<cci>]:PUSCh:FHOP:IIHB.....	154
CONFigure[LTE]:UL[:CC<cci>]:PUSCh:NOSM.....	154
CONFigure[LTE]:UL[:CC<cci>]:SUBFrame<subframe>:ALLoc:CONT.....	143
CONFigure[LTE]:UL[:CC<cci>]:SUBFrame<subframe>:ALLoc:MODulation.....	144
CONFigure[LTE]:UL[:CC<cci>]:SUBFrame<subframe>:ALLoc:PRECoding:CBINdex.....	144
CONFigure[LTE]:UL[:CC<cci>]:SUBFrame<subframe>:ALLoc:PRECoding:CLMapping.....	144
CONFigure[LTE]:UL[:CC<cci>]:SUBFrame<subframe>:ALLoc:PUCCh:FORMat.....	144
CONFigure[LTE]:UL[:CC<cci>]:SUBFrame<subframe>:ALLoc:PUCCh:NPAR.....	145
CONFigure[LTE]:UL[:CC<cci>]:SUBFrame<subframe>:ALLoc:PUSCh:CSField.....	145
CONFigure[LTE]:UL[:CC<cci>]:SUBFrame<subframe>:ALLoc:PUSCh:NDMRs.....	146
CONFigure[LTE]:UL[:CC<cci>]:SUBFrame<subframe>:ALLoc:RATO.....	146
CONFigure[LTE]:UL[:CC<cci>]:SUBFrame<subframe>:ALLoc:CLUSter<cluster>:RBCount.....	146
CONFigure[LTE]:UL[:CC<cci>]:SUBFrame<subframe>:ALLoc:CLUSter<cluster>:RBOFFset.....	146
CONFigure[LTE]:UL[:CC<cci>]:TDD:SPSC.....	140
CONFigure[LTE]:UL[:CC<cci>]:TDD:UDConf.....	140
DISPlay:FORMat.....	94
DISPlay[:WINDow<n>]:SIZE.....	94
DISPlay[:WINDow<n>]:TRACe<t>:Y[:SCALe]:AUTO ONCE.....	179
DISPlay[:WINDow<n>]:TRACe<t>:Y[:SCALe]:MAXimum.....	179
DISPlay[:WINDow<n>]:TRACe<t>:Y[:SCALe]:MINimum.....	179
DISPlay[:WINDow<n>]:TRACe<t>:Y[:SCALe]:RLEVel.....	163
DISPlay[:WINDow<n>]:TRACe<t>:Y[:SCALe]:RLEVel:OFFSet.....	163
FETCh:SUMMARY:EVM:SDQP[:AVERAge]?	118
FETCh:SUMMARY:EVM:SDSF[:AVERAge]?	118

FETCh:SUMMary:EVM:SDST[:AVERAge]?	118
FETCh:SUMMary:EVM:UCCD[:AVERAge]?	119
FETCh:SUMMary:EVM:UCCH[:AVERAge]?	119
FETCh:SUMMary:EVM:UPRA[:AVERAge]?	119
FETCh:SUMMary:EVM:USQP[:AVERAge]?	120
FETCh:SUMMary:EVM:USSF[:AVERAge]?	120
FETCh:SUMMary:EVM:USST[:AVERAge]?	120
FETCh:SUMMary:TFRame?	125
FETCh[:CC<cci>]:SUMMary:CRESt[:AVERAge]?	121
FETCh[:CC<cci>]:SUMMary:EVM:PCHannel:MAXimum?	122
FETCh[:CC<cci>]:SUMMary:EVM:PCHannel:MINimum?	122
FETCh[:CC<cci>]:SUMMary:EVM:PCHannel[:AVERAge]?	122
FETCh[:CC<cci>]:SUMMary:EVM:PSIGnal:MAXimum?	122
FETCh[:CC<cci>]:SUMMary:EVM:PSIGnal:MINimum?	122
FETCh[:CC<cci>]:SUMMary:EVM:PSIGnal[:AVERAge]?	122
FETCh[:CC<cci>]:SUMMary:EVM[:ALL]:MAXimum?	121
FETCh[:CC<cci>]:SUMMary:EVM[:ALL]:MINimum?	121
FETCh[:CC<cci>]:SUMMary:EVM[:ALL][:AVERAge]?	121
FETCh[:CC<cci>]:SUMMary:FERRor:MAXimum?	123
FETCh[:CC<cci>]:SUMMary:FERRor:MINimum?	123
FETCh[:CC<cci>]:SUMMary:FERRor[:AVERAge]?	123
FETCh[:CC<cci>]:SUMMary:GIMBalance:MAXimum?	123
FETCh[:CC<cci>]:SUMMary:GIMBalance:MINimum?	123
FETCh[:CC<cci>]:SUMMary:GIMBalance[:AVERAge]?	123
FETCh[:CC<cci>]:SUMMary:IQOffset:MAXimum?	123
FETCh[:CC<cci>]:SUMMary:IQOffset:MINimum?	123
FETCh[:CC<cci>]:SUMMary:IQOffset[:AVERAge]?	123
FETCh[:CC<cci>]:SUMMary:POWer:MAXimum?	124
FETCh[:CC<cci>]:SUMMary:POWer:MINimum?	124
FETCh[:CC<cci>]:SUMMary:POWer[:AVERAge]?	124
FETCh[:CC<cci>]:SUMMary:QUADerror:MAXimum?	124
FETCh[:CC<cci>]:SUMMary:QUADerror:MINimum?	124
FETCh[:CC<cci>]:SUMMary:QUADerror[:AVERAge]?	124
FETCh[:CC<cci>]:SUMMary:SERRor:MAXimum?	125
FETCh[:CC<cci>]:SUMMary:SERRor:MINimum?	125
FETCh[:CC<cci>]:SUMMary:SERRor[:AVERAge]?	125
FORMat[:DATA]	117
INITiate<n>:CONTInuous	102
INITiate<n>:SEQuencer:ABORt	103
INITiate<n>:SEQuencer:IMMEdiate	104
INITiate<n>:SEQuencer:MODE	104
INITiate<n>[:IMMEdiate]	103
INPut:ATTenuation	163
INPut:ATTenuation:AUTO	164
INPut:COUPling	164
INPut:FILTer:HPASs[:STATe]	159
INPut:FILTer:YIG[:STATe]	159
INPut:GAIN:STATe	164
INPut:IMPedance	165
INPut:SElect	160

INPut<n>:EATT.....	165
INPut<n>:EATT:AUTO.....	165
INPut<n>:EATT:STATe.....	166
INSTRument:CREate:DUPLicate.....	91
INSTRument:CREate:REPLace.....	91
INSTRument:CREate[:NEW].....	91
INSTRument:DELeTe.....	92
INSTRument:LIST?.....	92
INSTRument:REName.....	93
INSTRument[:SElect].....	93
LAYout:ADD[:WINDow]?.....	95
LAYout:CATalog[:WINDow]?.....	97
LAYout:IDENtify[:WINDow]?.....	97
LAYout:REMOve[:WINDow].....	97
LAYout:REPLace[:WINDow].....	98
LAYout:SPLitter.....	98
LAYout:WINDow<n>:ADD?.....	100
LAYout:WINDow<n>:IDENtify?.....	100
LAYout:WINDow<n>:REMOve.....	100
LAYout:WINDow<n>:REPLace.....	101
MMEMory:LOAD:DEModsetting.....	141
MMEMory:LOAD:IQ:STATe.....	137
MMEMory:LOAD:TMOD:DL.....	141
SYSTem:PRESet:CHANnel[:EXECute].....	137
SYSTem:SEQuencer.....	105
TRACe<n>[:DATA]?.....	115
TRIGger[:SEQuence]:HOLDoff<instrument>.....	169
TRIGger[:SEQuence]:LEVel<instrument>[:EXTernal].....	169
TRIGger[:SEQuence]:PORT<instrument>.....	169
TRIGger[:SEQuence]:SLOPe.....	169
TRIGger[:SEQuence]:SOURce.....	170
UNIT:BSTR.....	180
UNIT:CAXes.....	180
UNIT:EVM.....	181

Index

A

AC/DC coupling	67
ACLR	26
Allocation summary	20
Auto Demodulation	48
Auto Detection (Cell Identity)	45

B

Bit stream	21
------------------	----

C

Capture buffer	14
Capture Time	68
Carrier aggregation	76
CCDF	20
Cell ID	45
Cell Identity Group	45
Channel Bandwidth	43
Channel Estimation Range	71
Channel flatness group delay	18
Closing	
Channels (remote)	92
Windows (remote)	97, 100
Compensate DC Offset	72
Configurable Subframes	47
Configuration Table	47
Constellation diagram	19
Constellation Selection	80
Conventions	
SCPI commands	86
Copying	
Measurement channel (remote)	91
Coupling	
Input (remote)	164

D

Demodulation Reference Signal	
Delta Sequence Shift	54
Group Hopping	53
n _{DRMS}	54
Relative Power PUCCH	54
Relative Power PUSCH	53
Sequence Hopping	54
Duplicating	
Measurement channel (remote)	91

E

Evaluation methods	
Remote	95
EVM vs Carrier	14
EVM vs subframe	16
EVM vs symbol	15
EVM vs symbol x carrier	21
External Attenuation	66

F

Filters	
High-pass (remote)	159
YIG (remote)	159
Frame Number Offset	47
Frequency	64

H

Hardware settings	
Displayed	10
High-pass filter	
Remote	159

I

Identity (Physical Layer)	45
Impedance	
Remote	165
Setting	67
Inband emission	17
Input	
Coupling	67
Coupling (remote)	164
Installation	8

M

Marker table	
Evaluation method	25
Markers	
Querying position (remote)	127
Table (evaluation method)	25
Maximizing	
Windows (remote)	94
MC ACLR	28
Measurement	
ACLR	26
allocation summary	20
bit stream	21
capture buffer	14
CCDF	20
channel flatness grdel	18
constellation	19
EVM vs carrier	14
EVM vs subframe	16
EVM vs sym x carr	21
EVM vs symbol	15
inband emission	17
MC ACLR	28
numerical	22
power spectrum	16
power vs sym x carr	22
result summary	22
spectrum flatness	17
spectrum flatness difference	19
spectrum flatness SRS	18
spectrum mask	27
Measurement channel	
Creating (remote)	91
Deleting (remote)	92
Duplicating (remote)	91
Querying (remote)	92

Renaming (remote)	93
Replacing (remote)	91
Multicarrier filter	73
N	
Number of RB	43
Numerical results	22
O	
Options	
High-pass filter	159
Preamplifier (B24)	67
P	
Phase Error	70
Power spectrum	16
Power vs symbol x carrier	22
Preamplifier	
Setting	67
Softkey	67
Presetting	
Channels	41
PUCCH Structure	
Delta Shift	61
Format	61
N_PUCCH	61
N(1)_cs	60
N(2)_RB	61
Number of RBs for PUCCH	60
PUSCH Structure	
Frequency Hopping Mode	58
Info. in Hopping Bits	59
Number of Subbands	59
PUSCH Hopping Offset	59
R	
Reference Level	65
Remote commands	
Basics on syntax	86
Boolean values	89
Capitalization	87
Character data	90
Data blocks	90
Numeric values	89
Optional keywords	88
Parameters	88
Strings	90
Suffixes	87
Resource Blocks	43
Restoring	
Channel settings	41
Result Display	
Constellation Selection	80
Result displays	
Marker table	25
Result summary	22
RF input	
Remote	160
S	
Scrambling of coded bits	72
SEM requirement	75
Sequencer	
Aborting (remote)	103
Activating (remote)	104
Mode (remote)	104
Remote	102
Settings	
Auto	45
Auto Demodulation	48
Capture Time	68
Cell ID	45
Cell Identity Group	45
Channel Bandwidth	43
Channel Estimation Range	71
Compensate DC Offset	72
Conf. Index I_SRS	57
Configurable Subframes	47
Delta Sequence Shift	54
Delta Shift	61
Ext Att	66
Format	61
Frame Number Offset	47
Freq. Domain Pos. n_RRC	57
Frequency	64
Frequency Hopping Mode	58
Group Hopping	53
Hopping BW b_hop	56
Identity	45
Info. in Hopping Bits	59
multicarrier filter	73
n_DRMS	54
N_PUCCH	61
N(1)_cs	60
N(2)_RB	61
Number of RB	43
Number of RBs for PUCCH	60
Number of Subbands	59
Phase	70
Present	55
PUSCH Hopping Offset	59
Ref Level	65
Rel Power	57
Relative Power PUCCH	54
Relative Power PUSCH	53
Scrambling of coded bits	72
Sequence Hopping	54
SRS Bandwidth B_SRS	56
SRS BW Conf. C_SRS	57
SRS Cyclic Shift N_CS	56
SRS Subframe Conf.	56
Standard	42
suppressed interference synchronization	73
Swap I/Q	68
TDD UL/DL Allocations	44
Timing	71
Transm. Comb. K_TC	57
Signal source	
Remote	160
Slope	
Trigger	169
Softkey	
Const Selection	80
Softkeys	
Preamp	67
Sounding Reference Signal	
Conf. Index I_SRS	57
Freq. Domain Pos. n_RRC	57
Hopping BW b_hop	56

Present	55
Rel Power	57
SRS Bandwidth B_SRS	56
SRS BW Conf. C_SRS	57
SRS Cyclic Shift N_CS	56
SRS Subframe Conf.	56
Transm. Comb. K_TC	57
Specifics for	
Configuration	41
Spectrum flatness	17
Spectrum flatness difference	19
Spectrum flatness SRS	18
Spectrum mask	27
Standard Selection	42
Subframe Configuration Table	47
Suffixes	
Remote commands	87
Suppressed interference synchronization	73
Swap I/Q	68
T	
TDD UL/DL Allocations	44
Timing Error	71
Trigger	
External (remote)	170
Slope	169
U	
User manuals	6
W	
Window title bar information	10
Windows	
Adding (remote)	95
Closing (remote)	97, 100
Configuring	41
Layout (remote)	98
Maximizing (remote)	94
Querying (remote)	97
Replacing (remote)	98
Splitting (remote)	94
Types (remote)	95
Y	
YIG-preselector	
Activating/Deactivating	64
Activating/Deactivating (remote)	159